

Tools required  
Outillage necessaire  
Werkzeuge

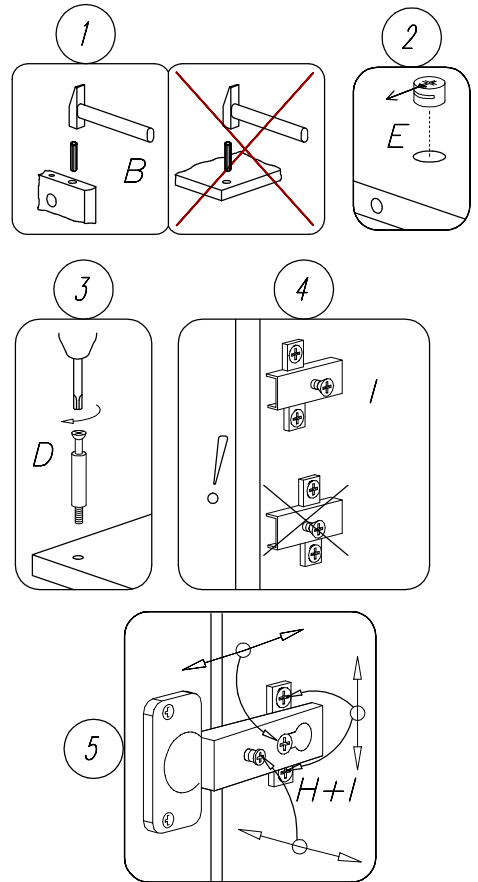

<p>A</p> <p>x2</p>	<p>B</p> <p>∅7,8x40 x30</p>	<p>C</p> <p>∅7x50 x3</p>	<p>D</p> <p>x17</p>	<p>E</p> <p>x17</p>	<p>F</p> <p>M6x55 x4</p>	<p>G</p> <p>x4</p>	<p>H</p> <p>GTV-II x6</p>	<p>I</p> <p>x6</p>	<p>J</p> <p>x16</p>	<p>K</p> <p>x4</p>	<p>L</p> <p>x10</p>	<p>M</p> <p>x4</p>
<p>N</p> <p>x25</p>	<p>O</p> <p>∅3x12 x8</p>	<p>P</p> <p>∅3,5x30 x6</p>	<p>R</p> <p>∅4x16 x12</p>	<p>S</p> <p>∅3,5x25 x4</p>	<p>T</p> <p>M6x75 x4</p>	<p>U</p> <p>x8</p>	<p>V</p> <p>M6 x8</p>	<p>W1</p> <p>∅3,5x16 x44</p>	<p>W2</p> <p>x22</p>	<p>X</p> <p>x1</p>	<p>Y</p> <p>x1</p>	

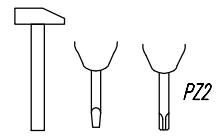
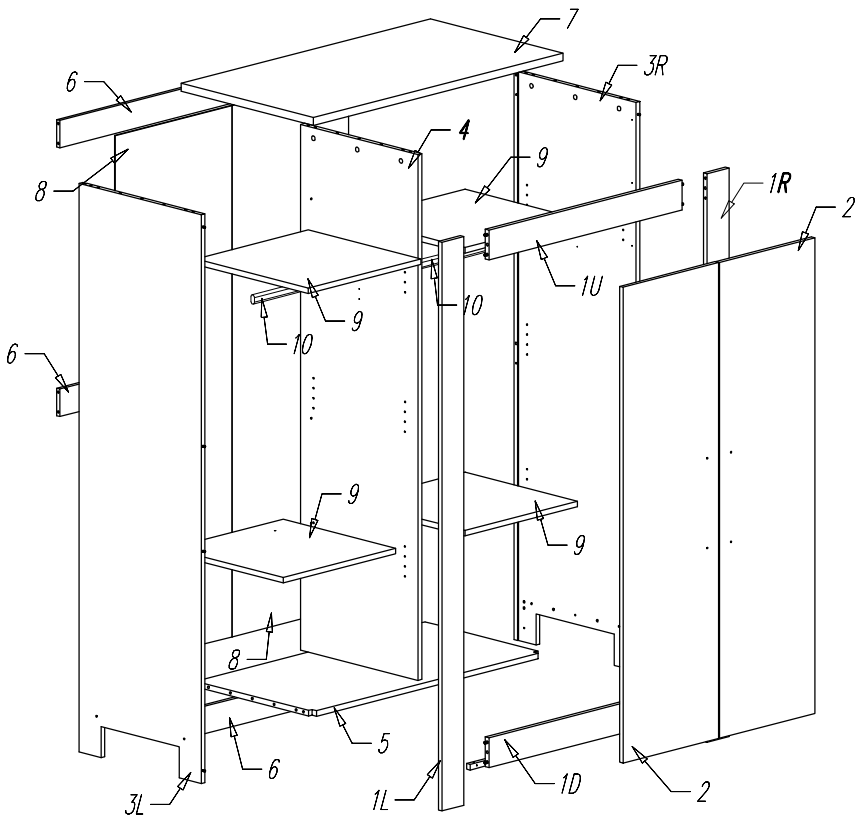

**Colli 1/3:**

Part no. 1L+1R -1+1 pcs/St.

Part no. 1U+1D -1+1 pcs/St.

Part no. 2 -2 cs/St.

Fittings/Beschläge

Assembly instruction/Montageanleitung

**Colli 2/3:**

Part no. 3L -1 pcs/St.

Part no. 3R -1 pcs/St.

Part no. 4 -1 pcs/St.

Part no. 8 -2 pcs/St.

**Colli 3/3:**

Part no. 5 -1 cs/St.

Part no. 6 -3 cs/St.

Part no. 7 -1 cs/St.

Part no. 9 -4 pcs/St.

Part no. 10 -2 pcs/St.

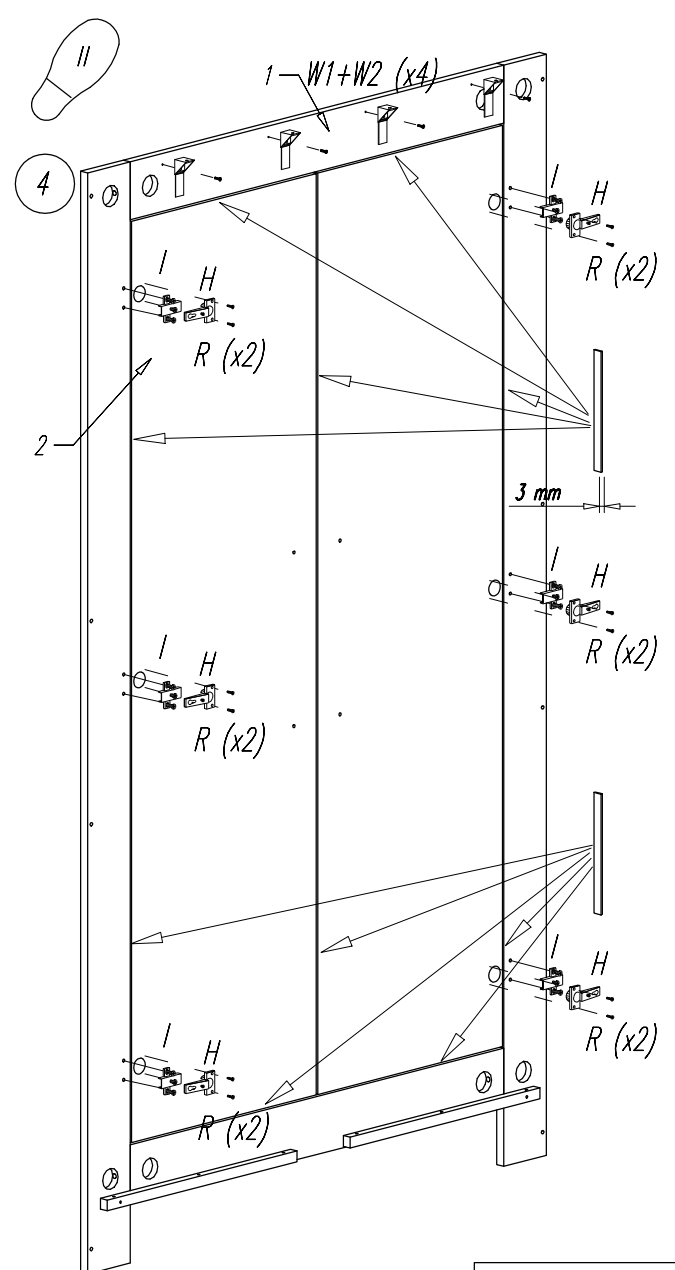
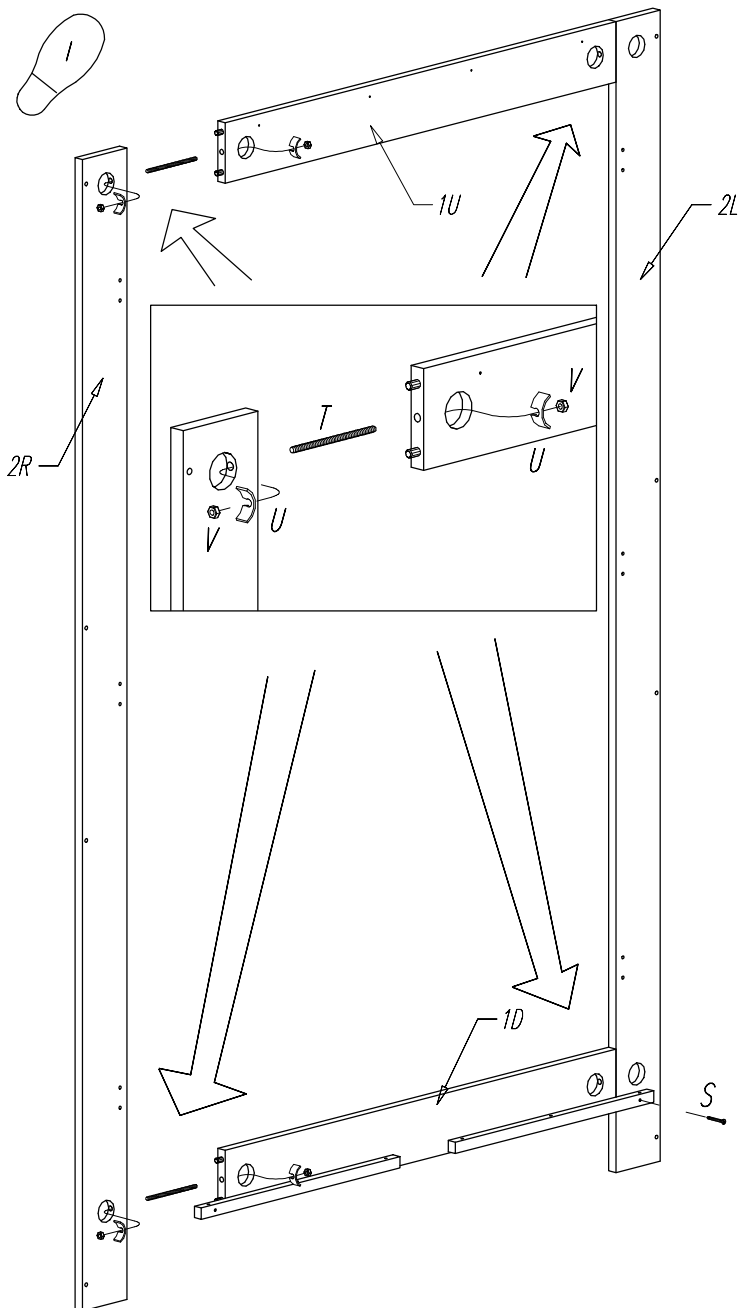

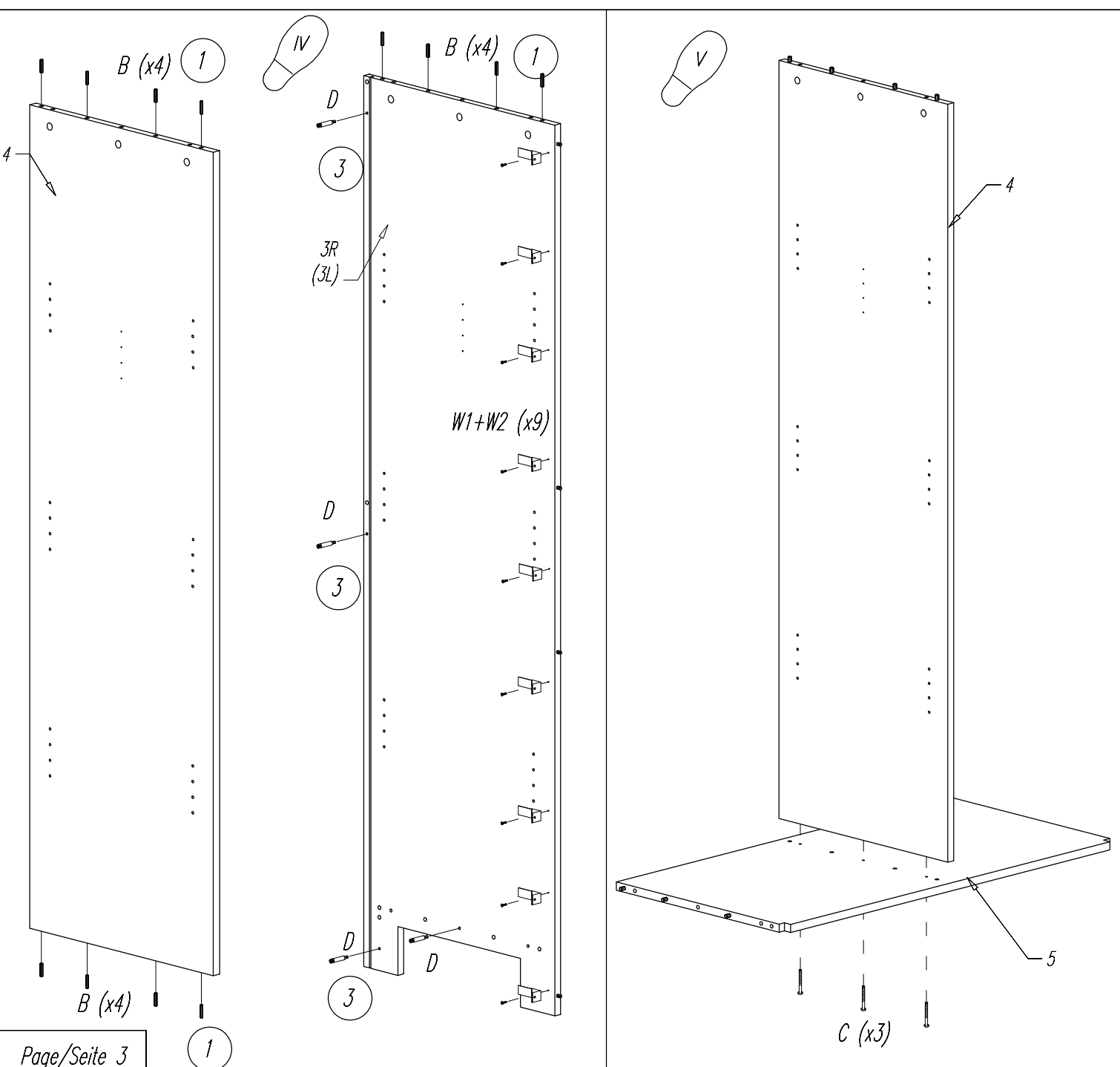
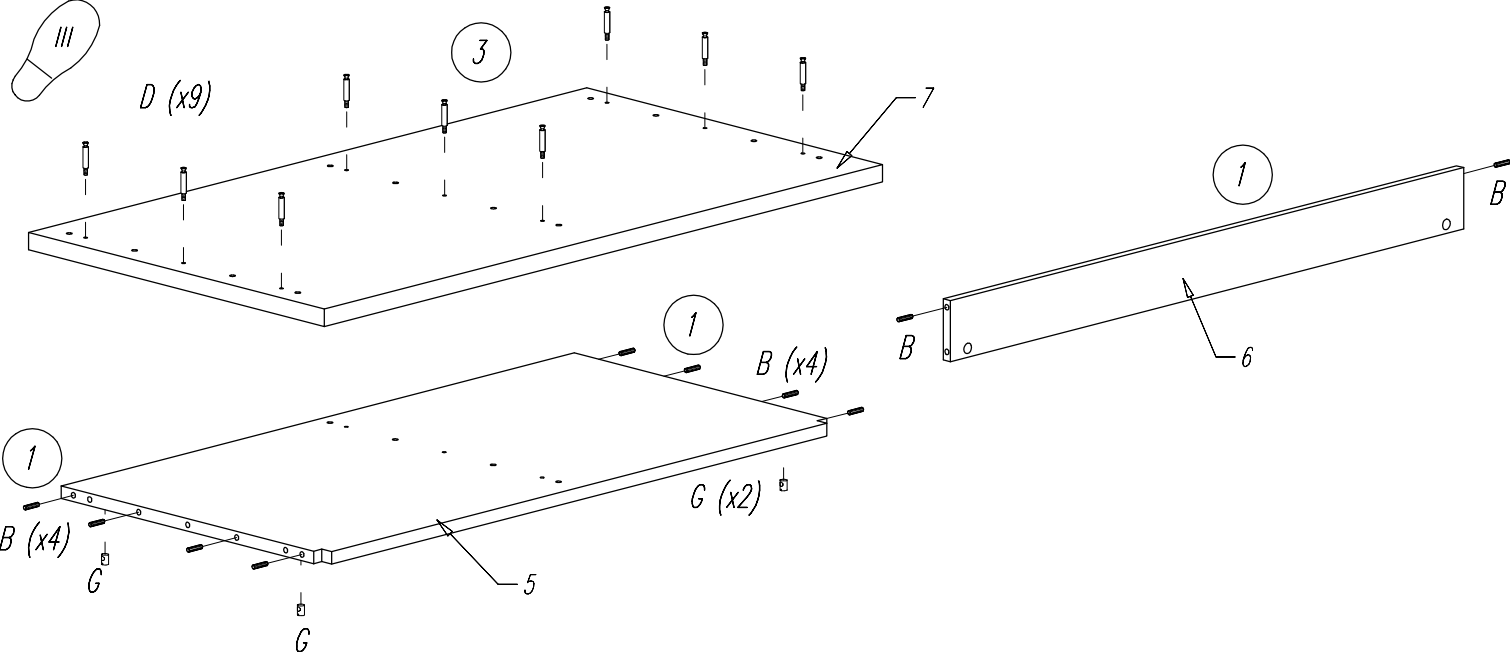

VI

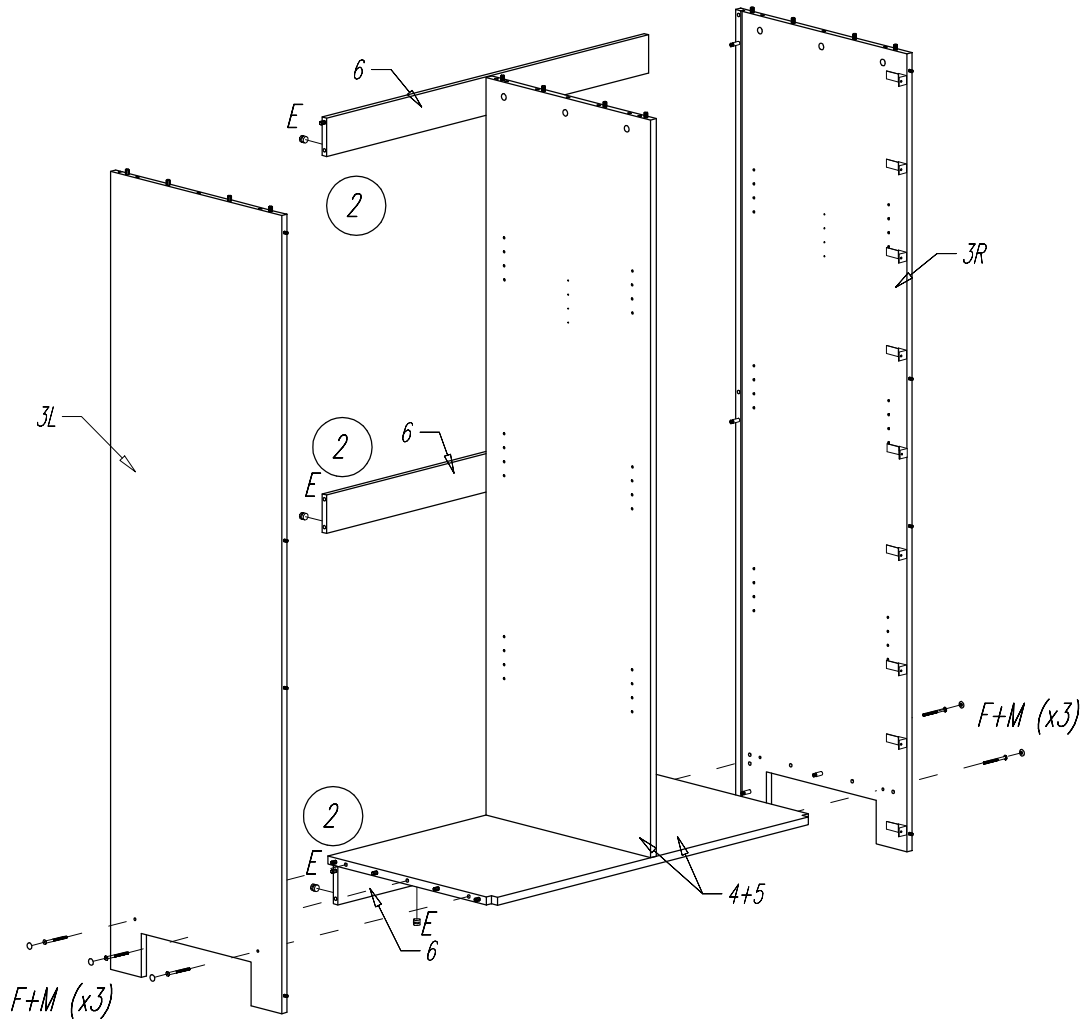

VII

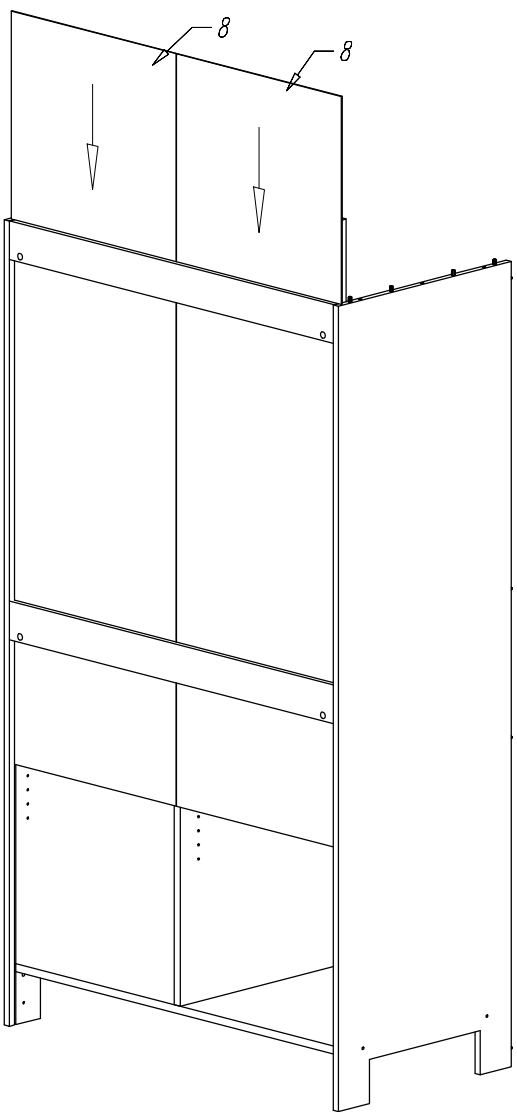

VIII

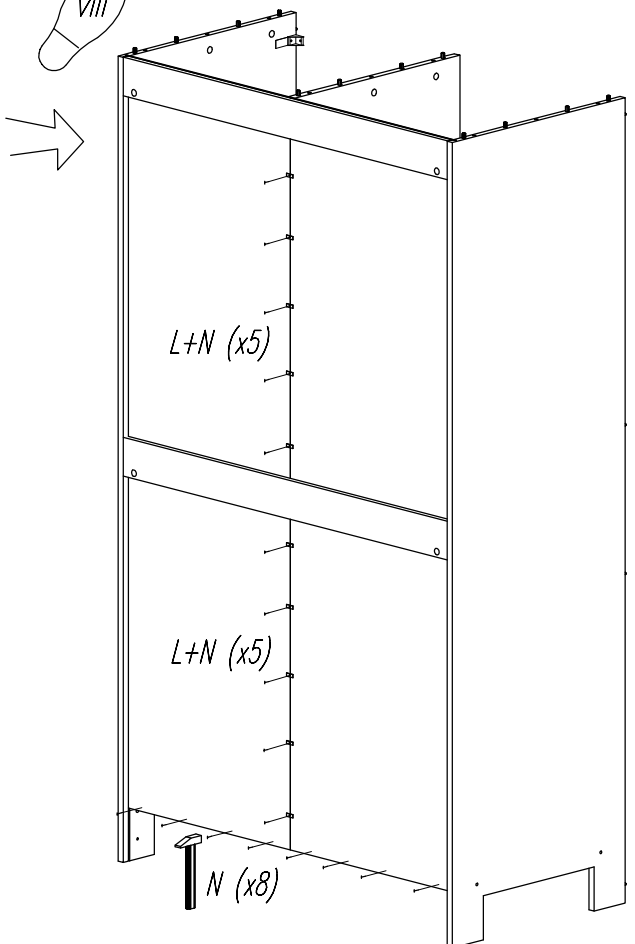

IX

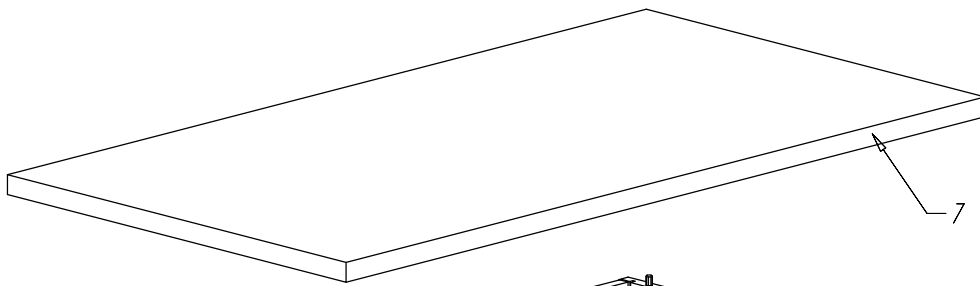

2

