

OAKIE R1

DE: Montageanleitung

CZ: Návod k montáži

ES: instrucciones de montaje

GB: Assembly instructions

NL: Montagehandleiding

FR: Notice de montage

PL: Instrukcja montażu

SK: Návod na montáž

RO: Instrucțiuni de montaj

SE: Monteringsanvisningar

UA: Керівництво з монтажу

GR: Οδηγίες συναρμολόγησης

SI: Navodila za montažo

HR: Upute za montažu

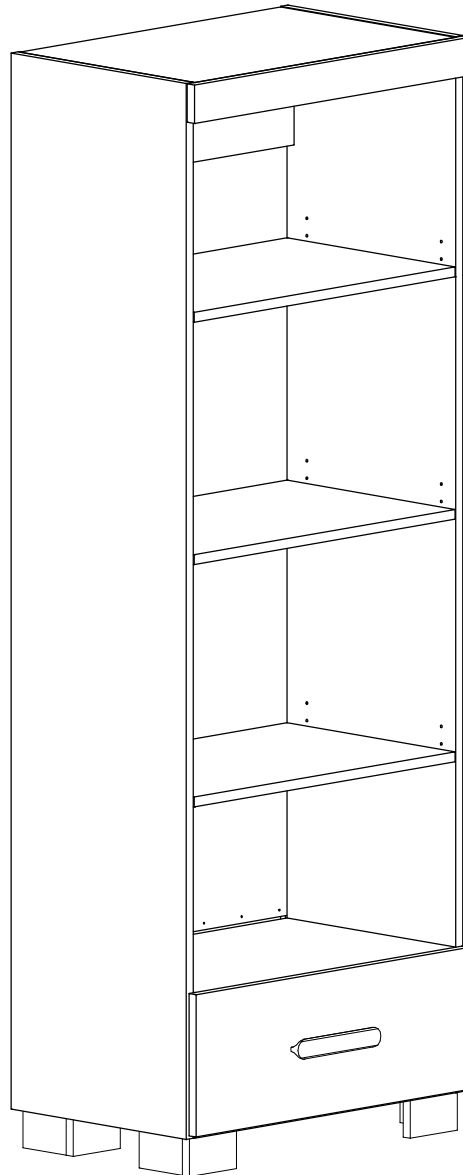

Narzędzia
Tools required
Outilsage nécessaire
Werkzeuge
Delovno orodje
Alat

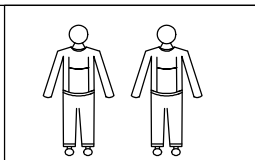
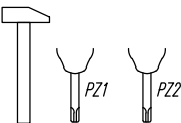

Ostrzeżenie! Nie pozostawiać dzieci bez opieki w pobliżu mebli podczas montażu. Małe części, niebezpieczeństwo uduszenia.

Warning! Do not leave children unattended near furniture during installation. Small parts, the danger of suffocation.









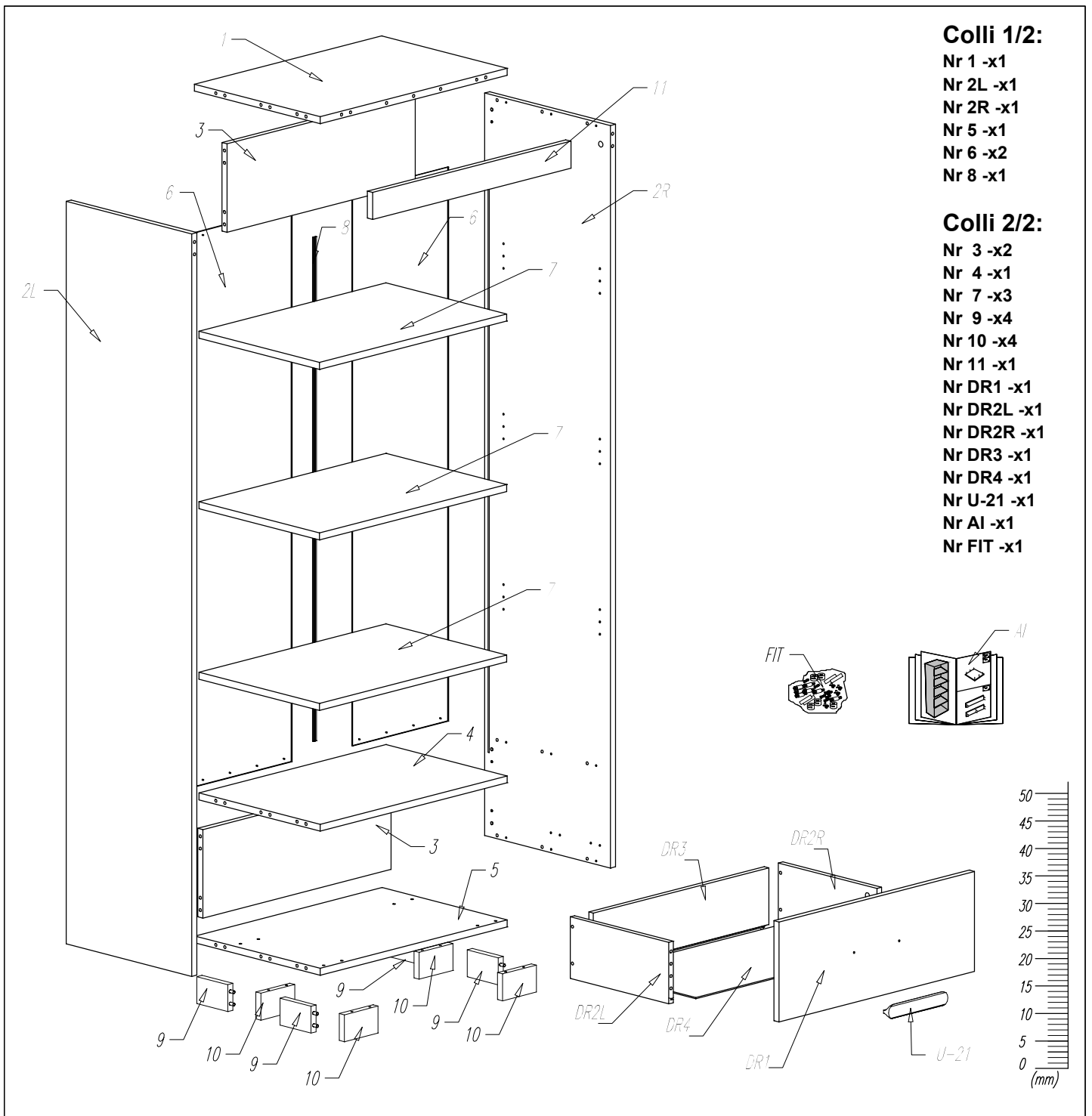

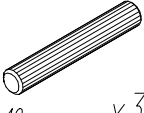
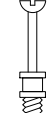



Achtung! Lassen Sie Kinder nicht unbeaufsichtigt in der Nähe von Möbel während der Installation. Kleine Teile, die Gefahr des Erstickens.

Attention! Ne laissez pas les enfants sans surveillance à proximité des meubles lors de leur montage. Les petites pièces peuvent présenter un risque de suffocation.

Opozorilo! Otroka ne puščajte brez nadzora staršev med montažo.

Upozorenje! Dijete ne puštajte bez nadzora roditelja tijekom montaže.

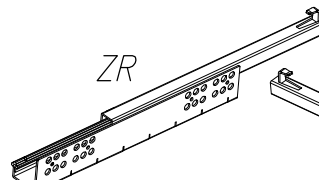
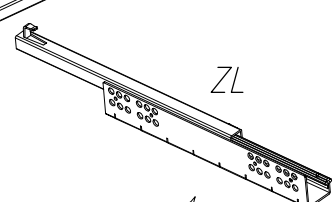

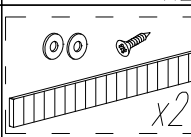
A  ∅8x40 x36	B  L34/St x35	C  ∅15/16 x35	D  ∅17 Biate x4	E  ∅3.5x30 x2	F  ∅18 dqb x2	G  ∅6,3x40 x8
H  x12	K  ∅3,5x16 x16	L  x4	M  ∅6x11 x8	N  ∅7x50 x4	O  ∅3,0x16 x2	P  x1
ZR 		ZL 		 www.pinio.com.pl x1	 SW4 x1	 x2
2/8 FAVORIT-Q/L-350 x1		OAKIE R1				

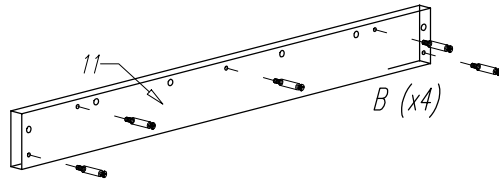
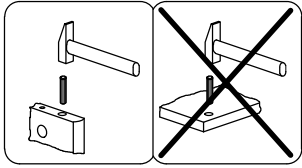
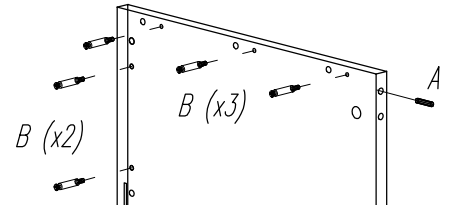
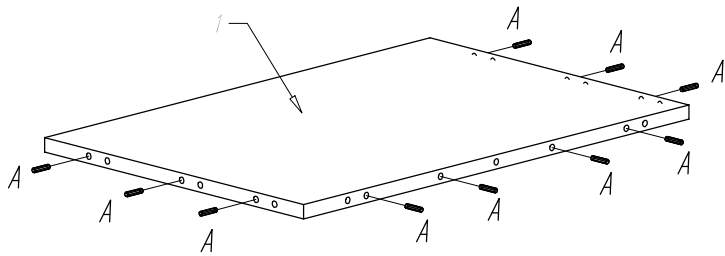

2L+(2R)

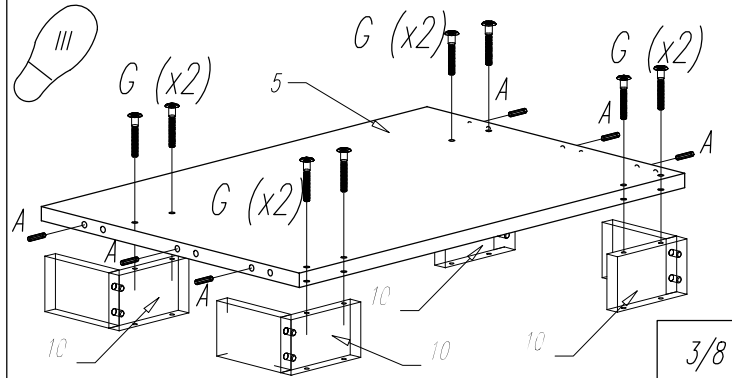
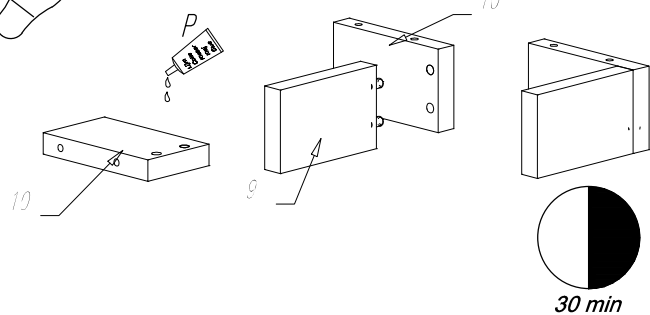
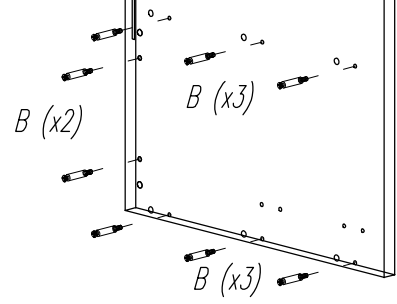
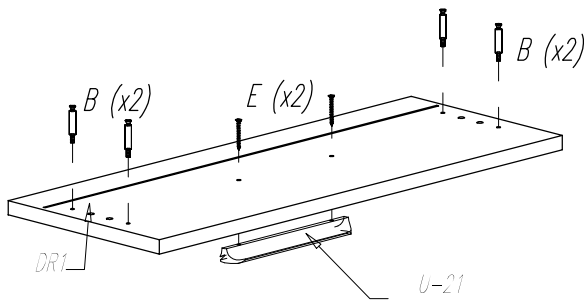
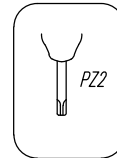
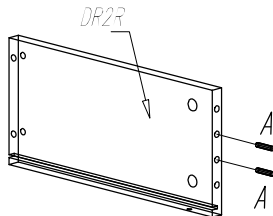
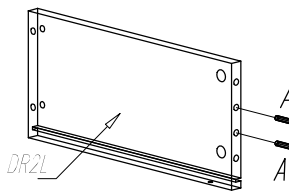
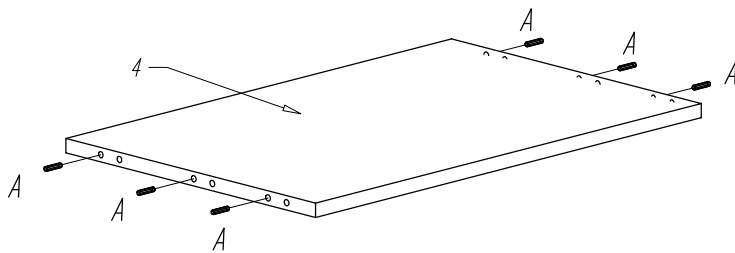
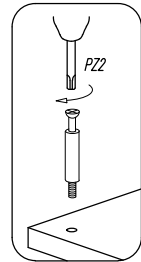
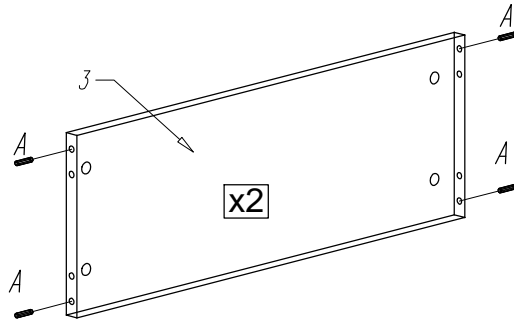

IV

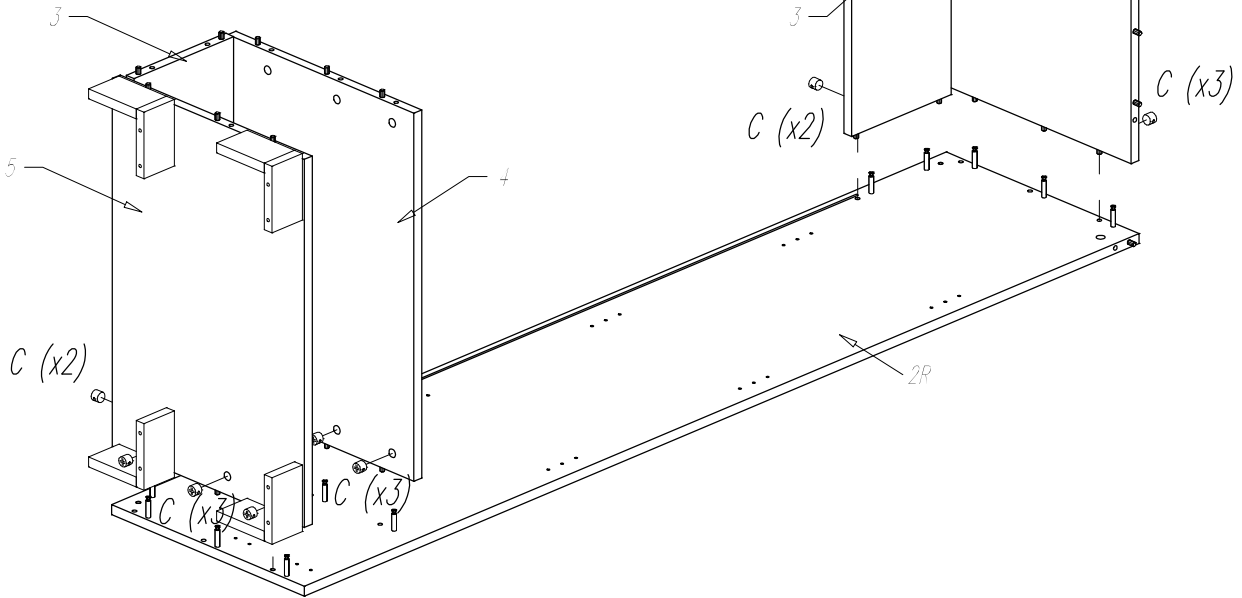
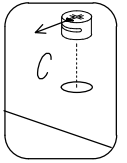
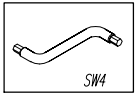

V

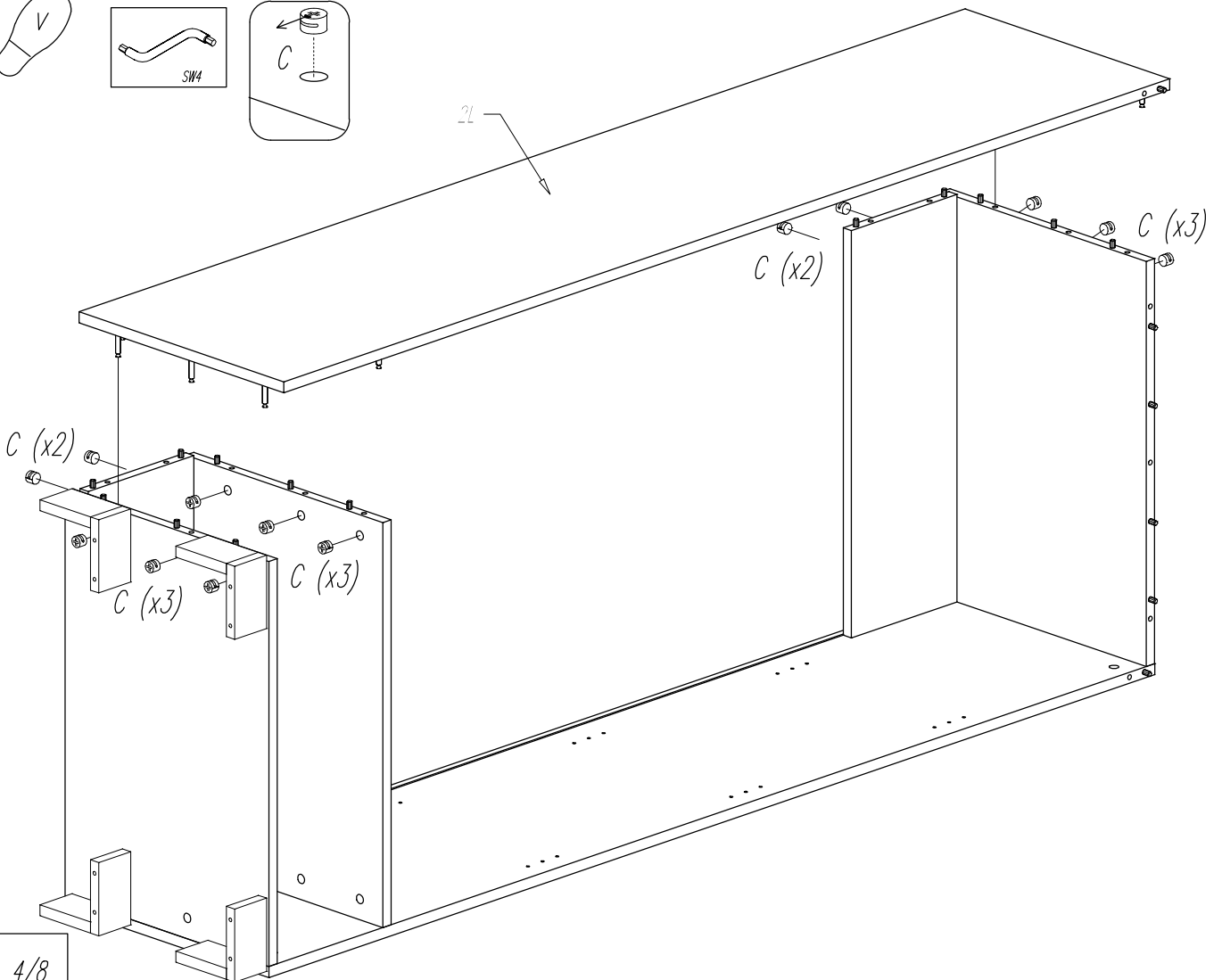
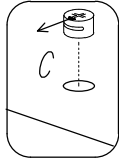
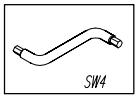

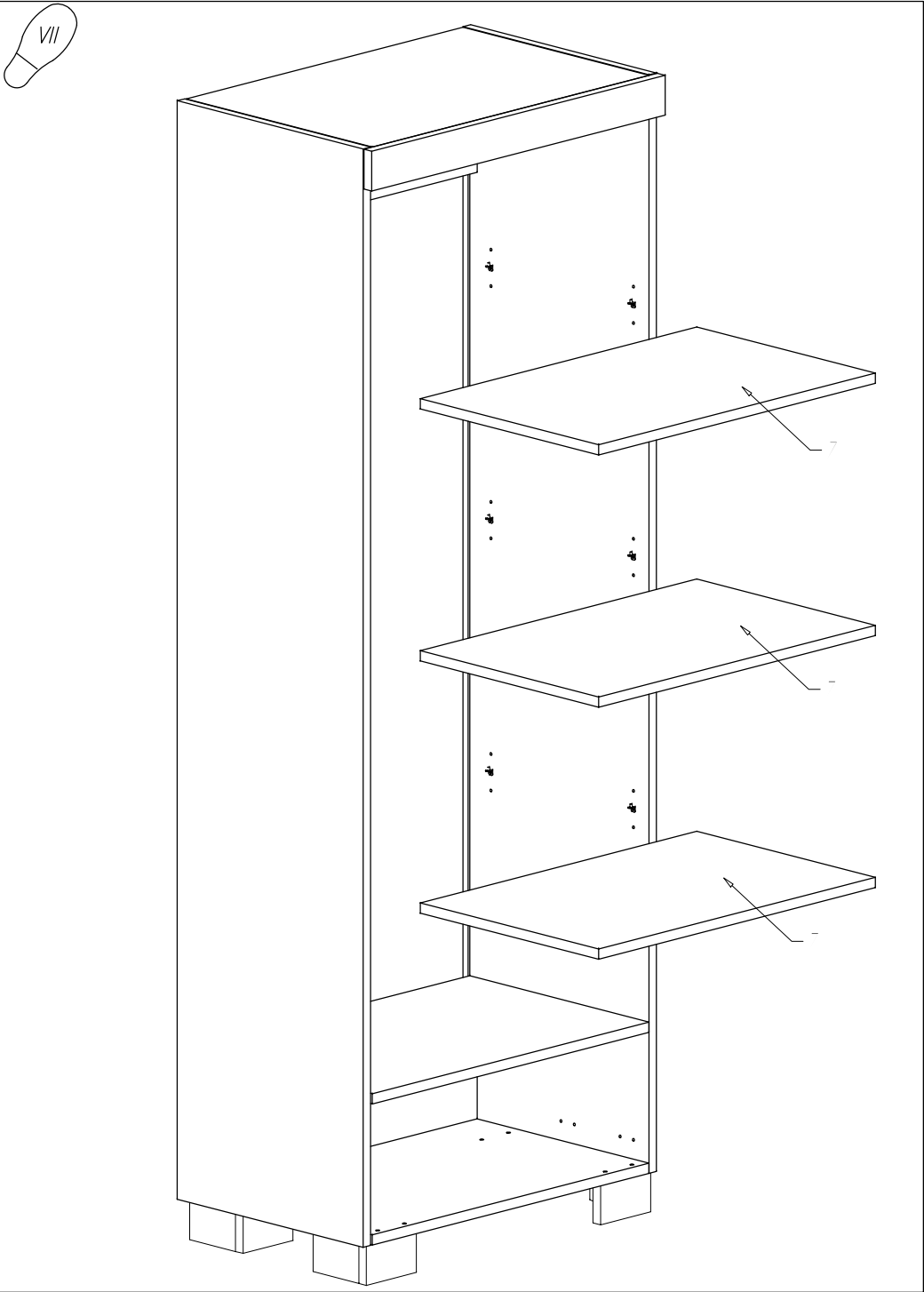
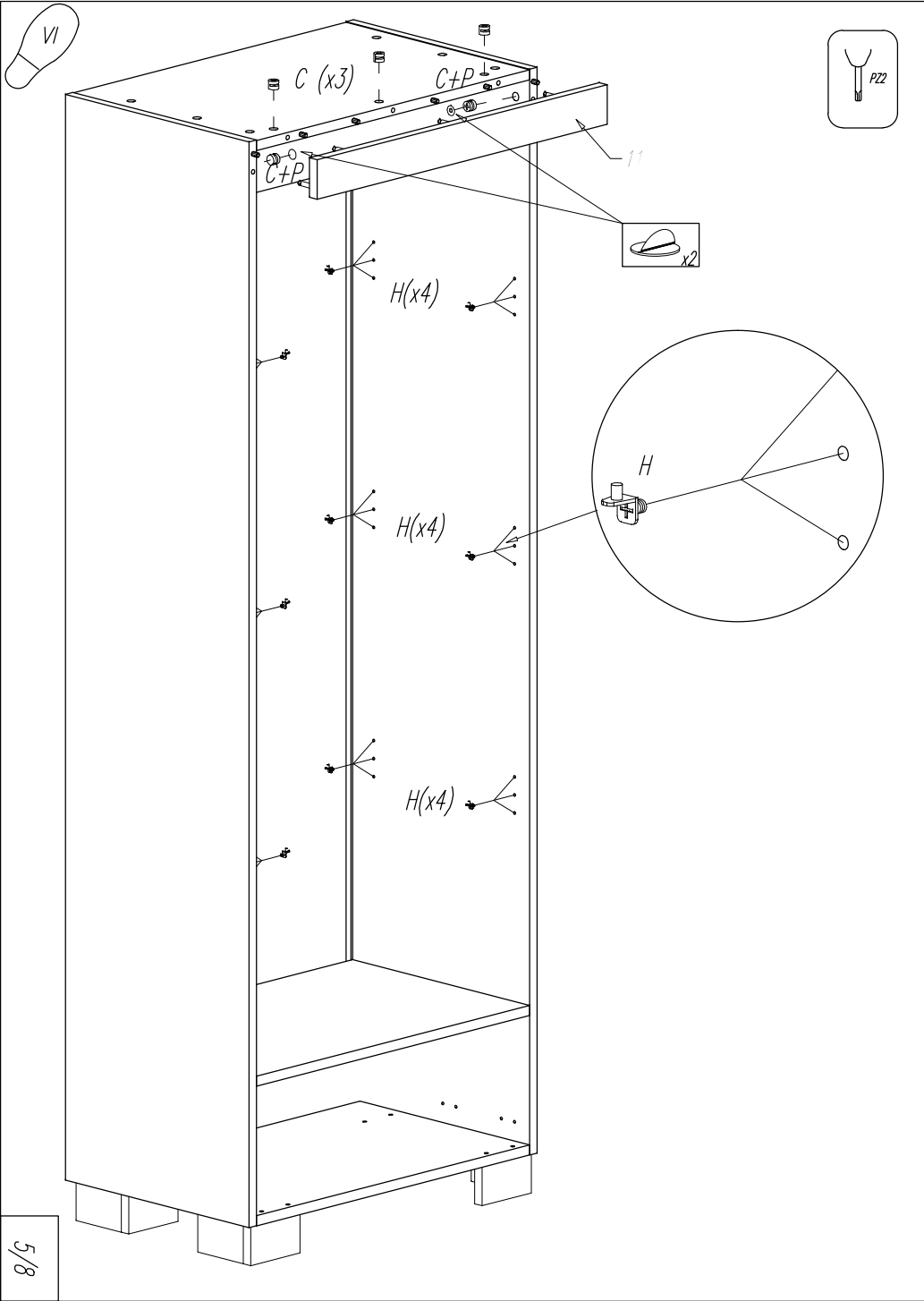

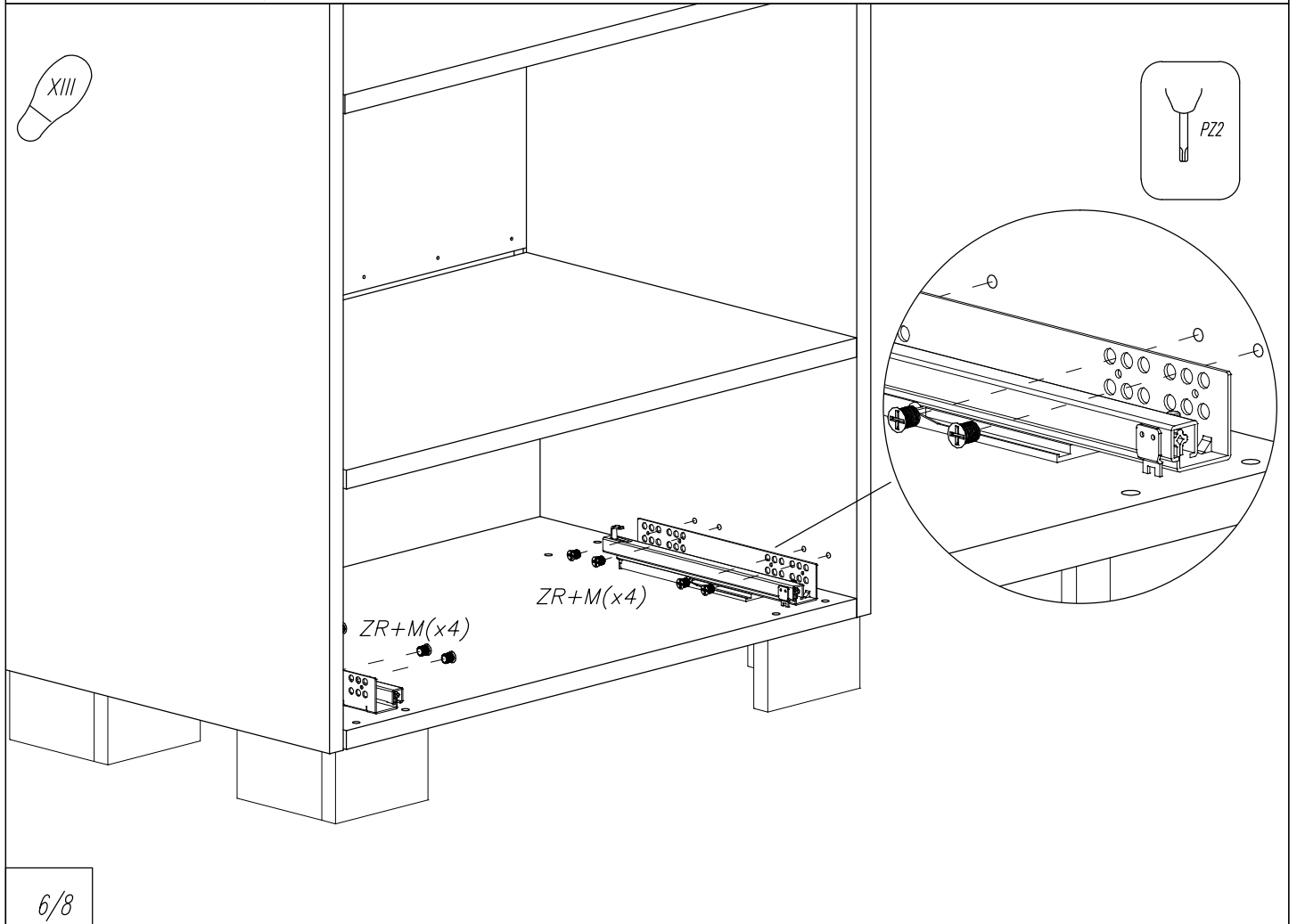
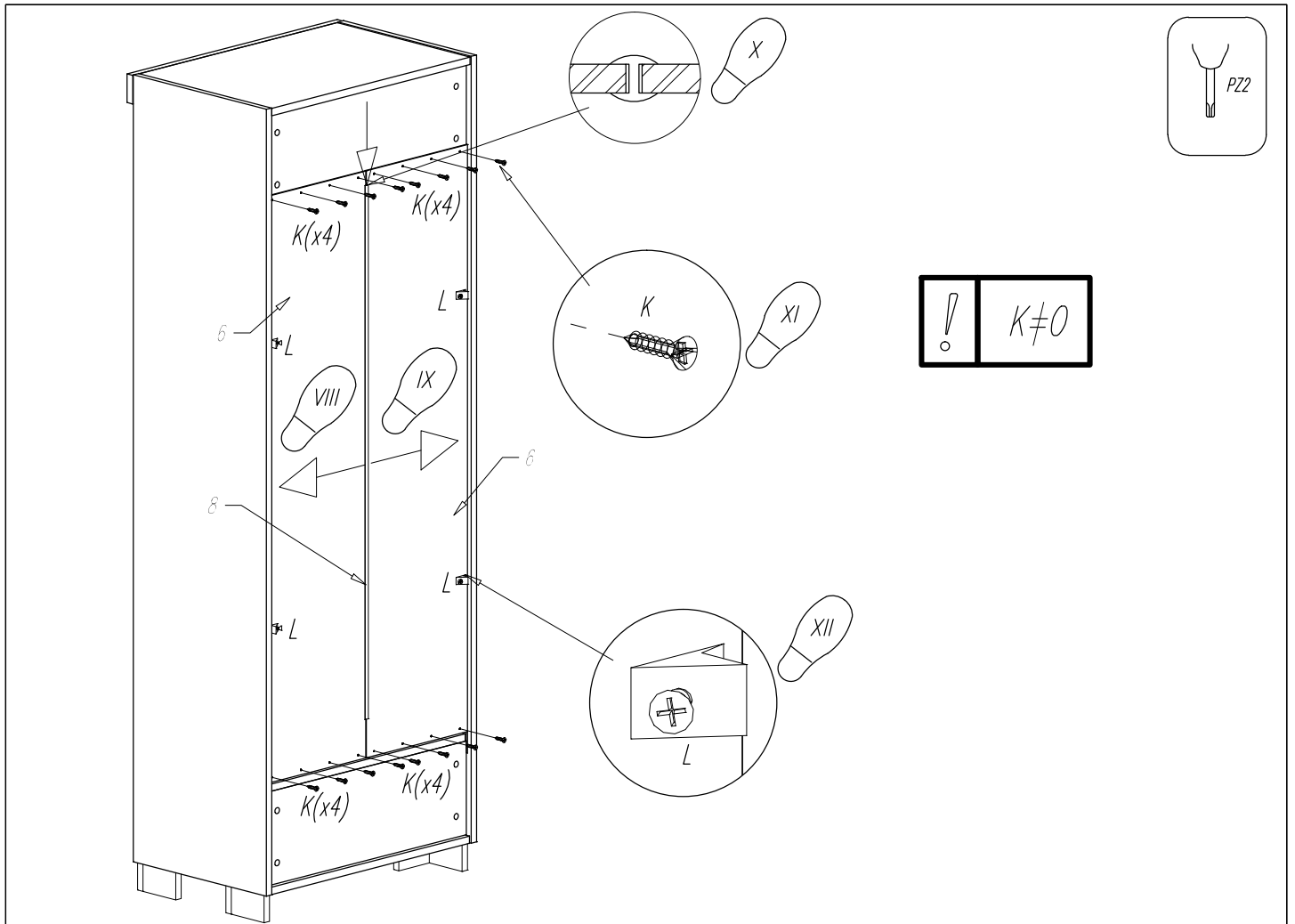

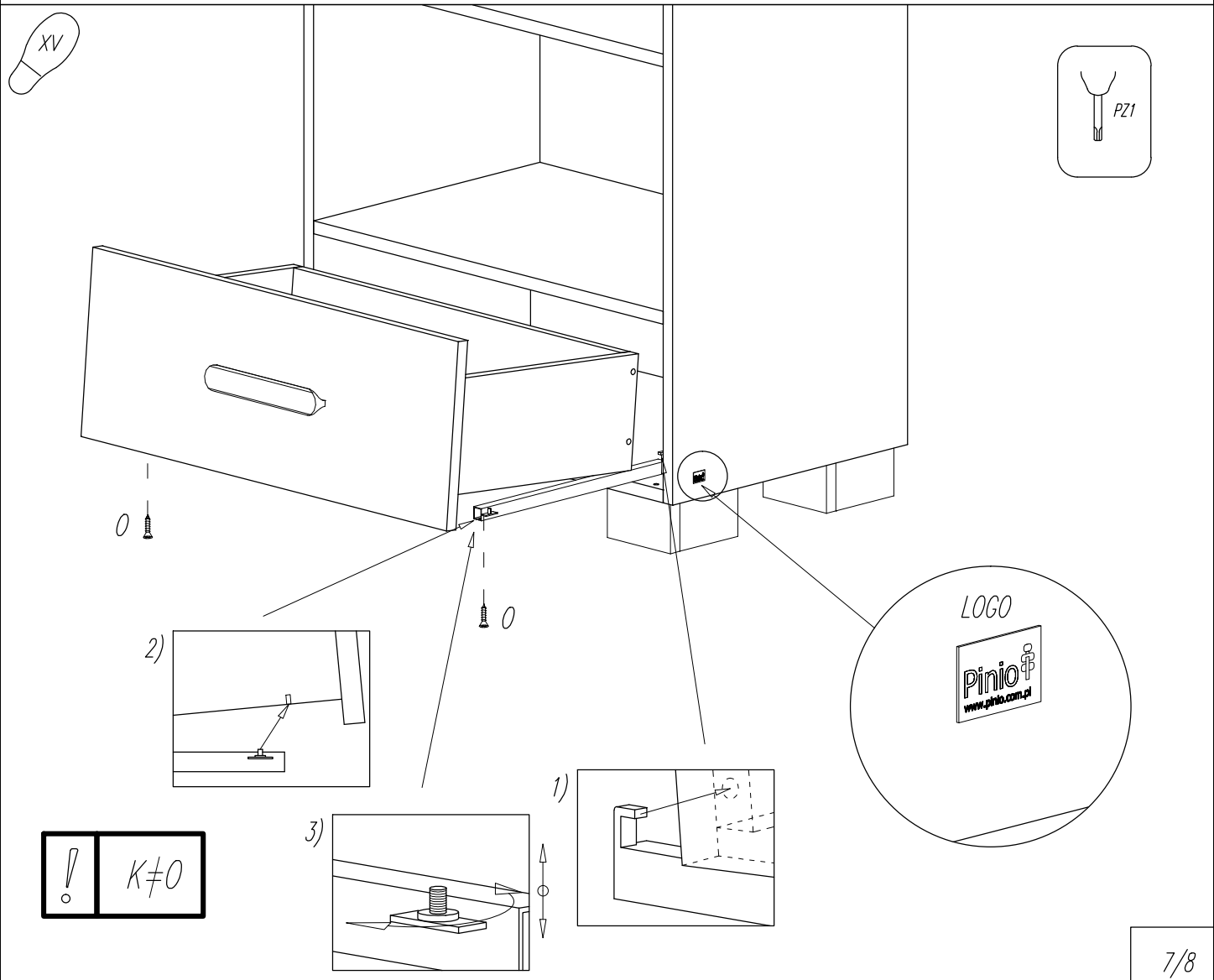
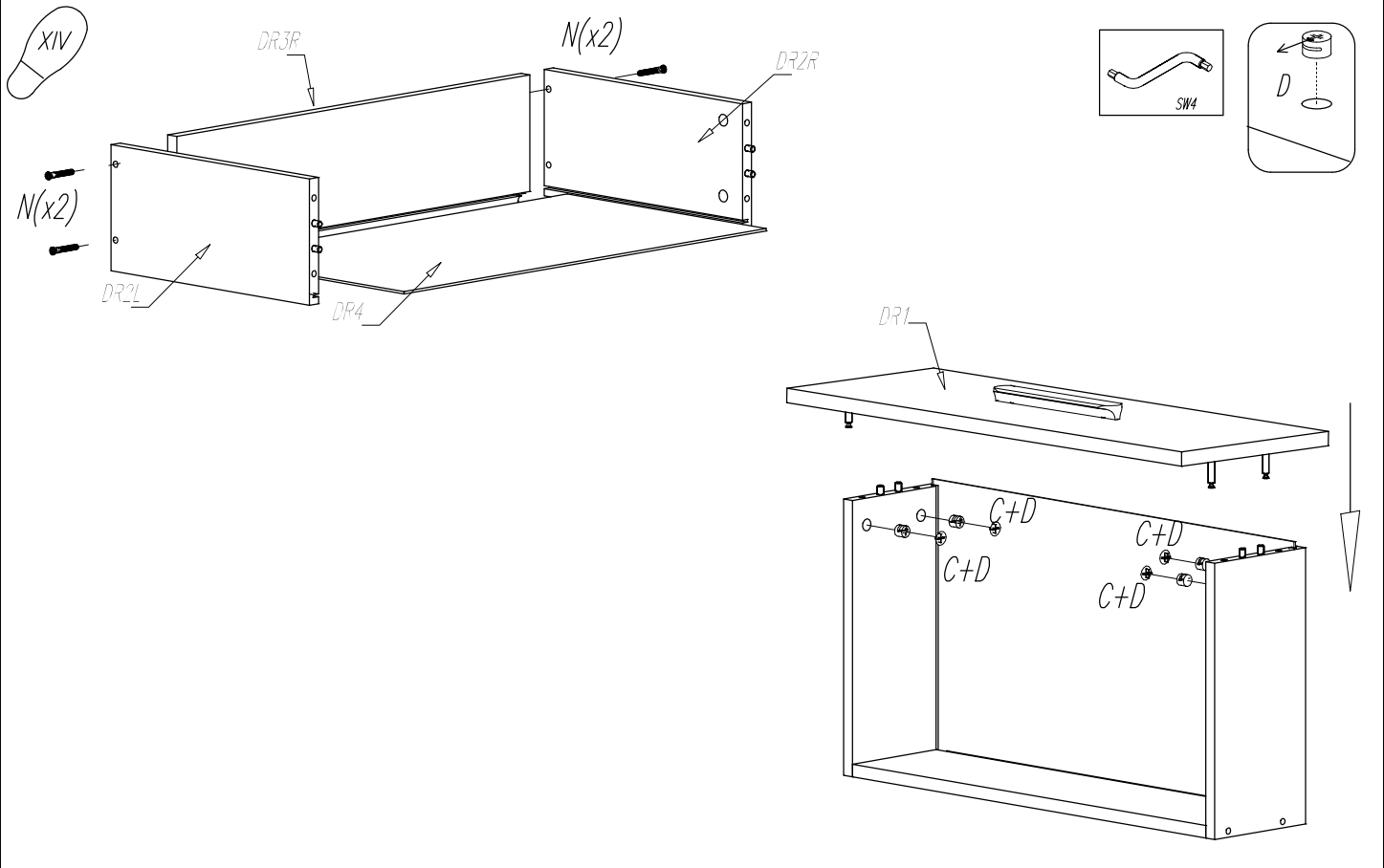



Zabezpieczenie przed przewracaniem

Kippsicherung

Prevention of tipping over

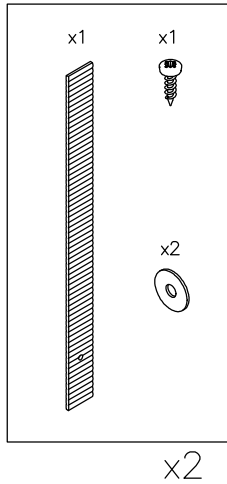
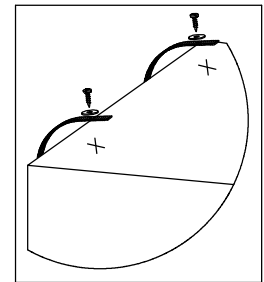
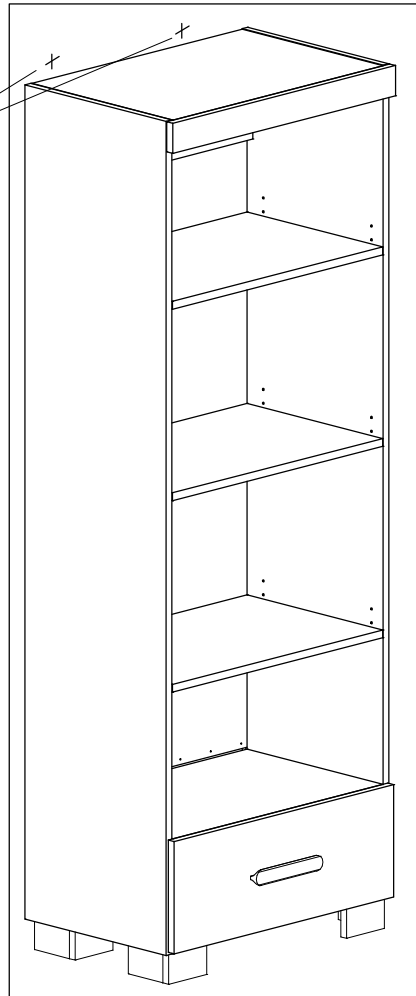
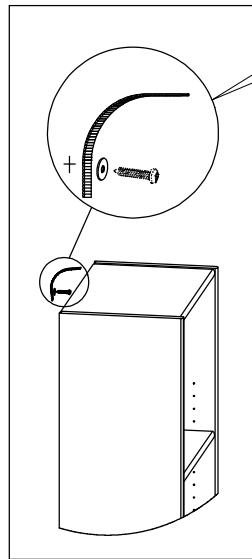
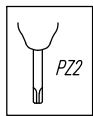

DE

WICHTIG: Die beigelegten Schrauben sind ausschließlich für die Befestigung des Kippschutzes am Möbelstück vorgesehen. Für die Befestigung des Kippschutzes an der Wand benötigen Sie zusätzlich Schrauben oder Beschläge, die zur Beschaffenheit der Wand passen. Falls Sie sich nicht sicher sind, welche Art von Schrauben geeignet sind, wenden Sie sich bitte an den Fachhandel

PL

UWAGA! W komplecie z mocowaniami zapobiegającymi wywróceniu mebla są śruby, które służą tylko do przytwierdzenia ich do mebla. Rodzaj śrub przytwierdzających je do ściany zależy od rodzaju materiału z jakiego została wykonana (gips, cegła, drewno itd.). Będą więc potrzebne dodatkowo odpowiednie śruby. Jeśli masz wątpliwości co do rodzaju śrub zasięgnij opinii fachowca.

GB

IMPORTANT. The screw supplied together with the anti-topple bracket is to be used only for fixing the anti-topple bracket to the furniture. In addition to this, you will need to choose a screw or fitting which is suitable for securing the bracket to the kind of walls you have. If you are unsure about what type of screw to use contact your local hardware store.

FR

IMPORTANT : la vis fournie avec le dispositif anti-bas-ule est destinée à fixerle dispositif dans le meuble. Pour la fixation au mur, compléter par une vis adaptée au support mural. En cas de doute, contacter un magasin de bricolage.

NL

BELANGRIJK. De schroeven die bij de wandbevestiging zitten, zijn uitsluitend bedoeld om de wandbevestiging aan het meubel te bevestigen. Completeer de wandbevestiging met een schroef of bevestigingsbeslag dat geschikt is voor het materiaal van de wand. Neem bij twijfel contact op met de ijzerhandel.

SI

DÔLEŽITÉ UPOZORNENIE. Skrutka dodávaná spolu s bezpečnostným kovaním je urpčna iba na upevnenie kovania k naábytku. okrem toho budete potrebovat skrutku za prichytenie kovania k stene. Túto si vyberte podľa druhu steny. AK si nie ste istý, aký, druh skrutky potrebujete, kontaktujte najbližšie železiarstvo.