

OAKIE W3

DE: Montageanleitung

CZ: Návod k montáži

ES: instrucciones de montaje

GB: Assembly instructions

NL: Montagehandleiding

FR: Notice de montage

PL: Instrukcja montażu

SK: Návod na montáž

RO: Instrucțiuni de montaj

SE: Monteringsanvisningar

UA: Керівництво з монтажу

GR: Οδηγίες συναρμολόγησης

SI: Navodila za montažo

HR: Upute za montažu

wer. A

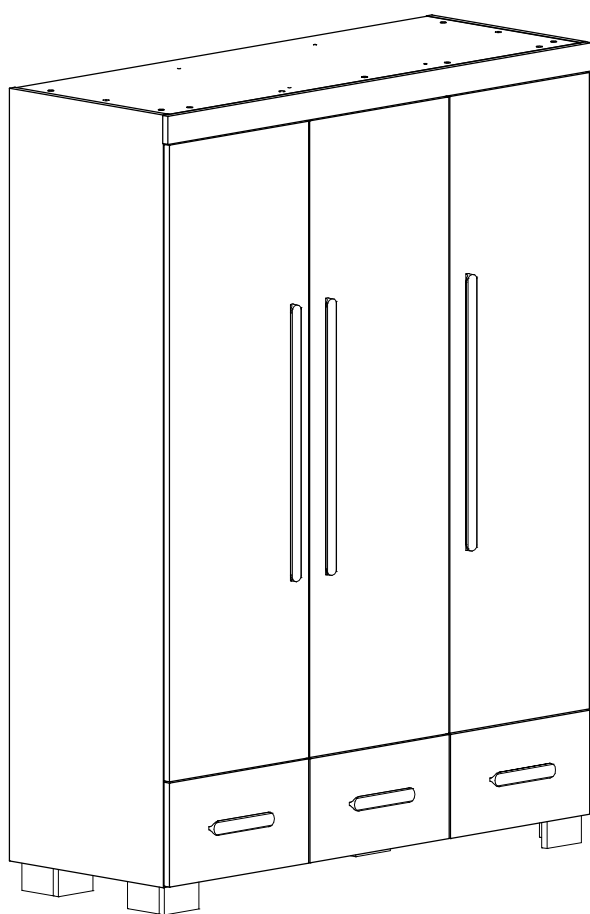

wer. B

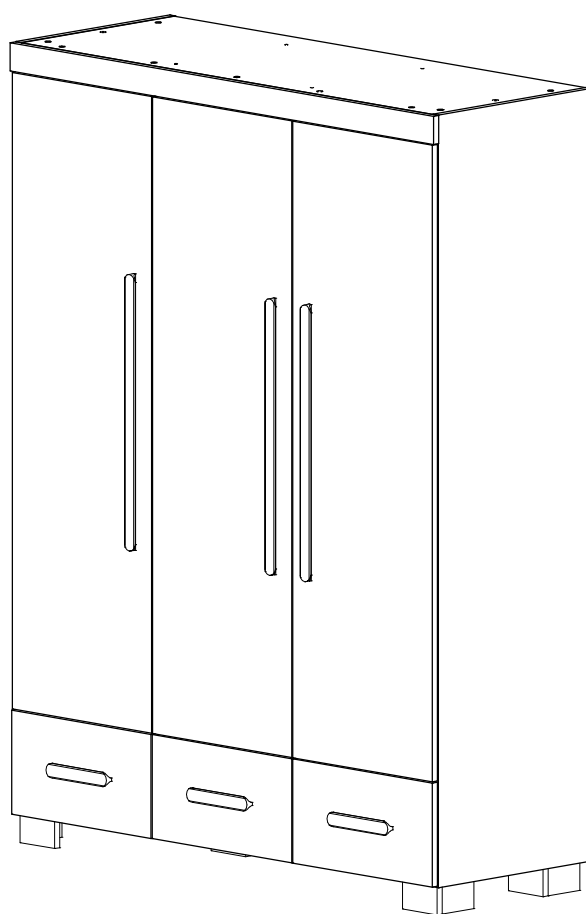

Narzędzia
Tools required
Outillage nécessaire
Werzeuge
Delovno orodje
Alat

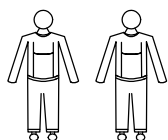
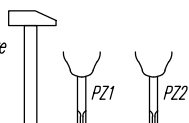

Ostrzeżenie! Nie pozostawiać dzieci bez opieki w pobliżu mebli podczas montażu. Małe części, niebezpieczeństwo uduszenia.

Warning! Do not leave children unattended near furniture during installation. Small parts, the danger of suffocation.

Achtung! Lassen Sie Kinder nicht unbeaufsichtigt in der Nähe von Möbel während der Installation. Kleine Teile, die Gefahr des Erstickens.

Attention! Ne laissez pas les enfants sans surveillance à proximité des meubles lors de leur montage. Les petites pièces peuvent présenter un risque de suffocation.

Opozorilo! Otroka ne puščajte brez nadzora staršev med montažo.

Upozorenje! Dijete ne puštajte bez nadzora roditelja tijekom montaže.

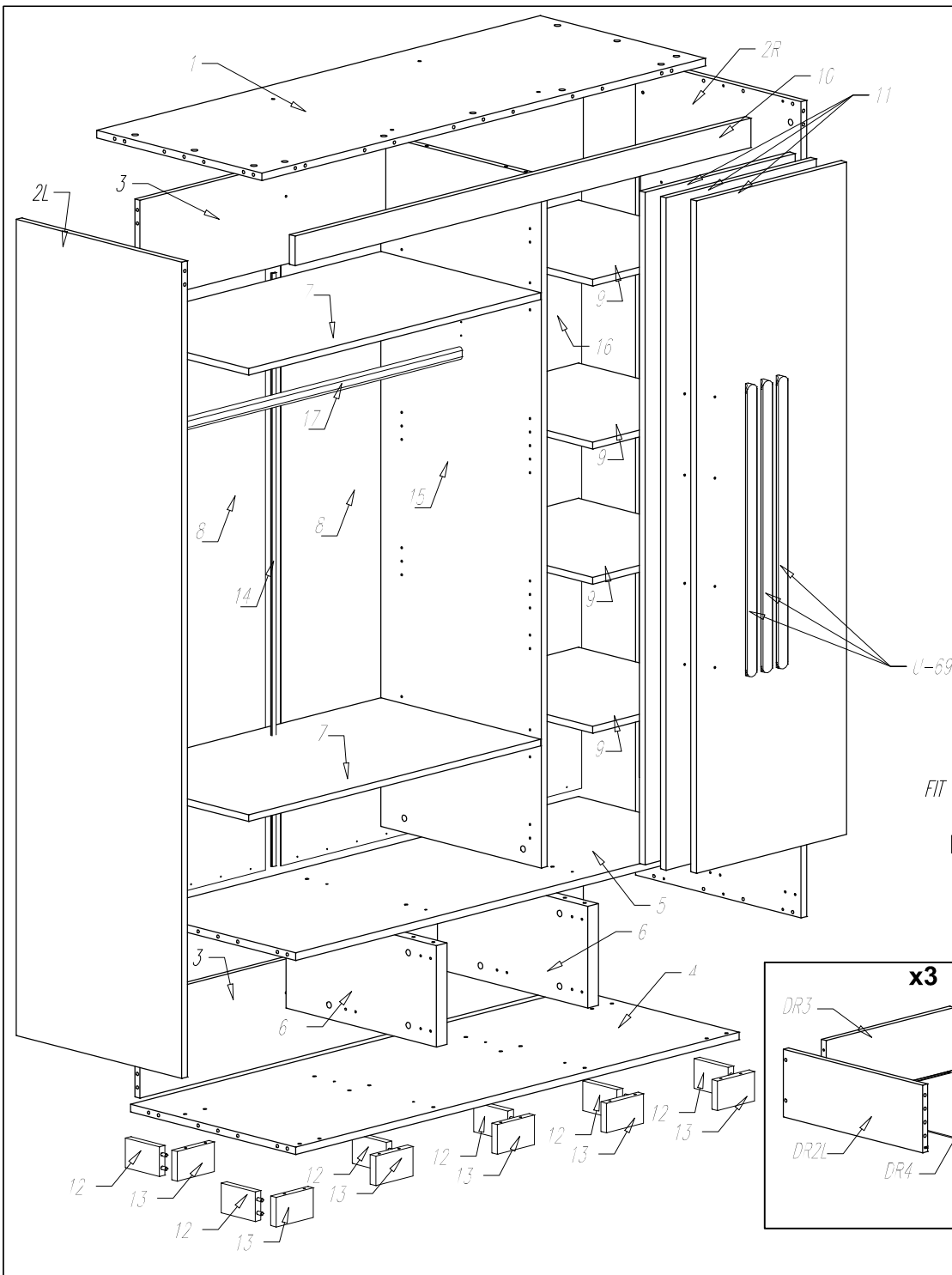

- Colli 1/6:**
 Nr 2L -x1
 Nr 2R -x1
- Colli 2/6:**
 Nr 8 -x2
 Nr 11 -x2
 Nr 14 -x1
- Colli 3/6:**
 Nr 1 -x1
 Nr 3 -x2
 Nr 4 -x1
 Nr 10 -x1
 Nr 16 -x1
 Nr U-21 -x2
 Nr U-69 -x2
- Colli 4/6:**
 Nr 5 -x1
 Nr 11 -x1
 Nr 15 -x1
- Colli 5/6:**
 Nr 6 -x2
 Nr 7 -x2
 Nr 9 -x4
 Nr 17 -x1
- Colli 6/6:**
 Nr 12 -x6
 Nr 13 -x6
 Nr DR1 -x3
 Nr DR2L -x3
 Nr DR2R -x3
 Nr DR3 -x3
 Nr DR4 -x3
 Nr AI -x1
 Nr FIT -x1

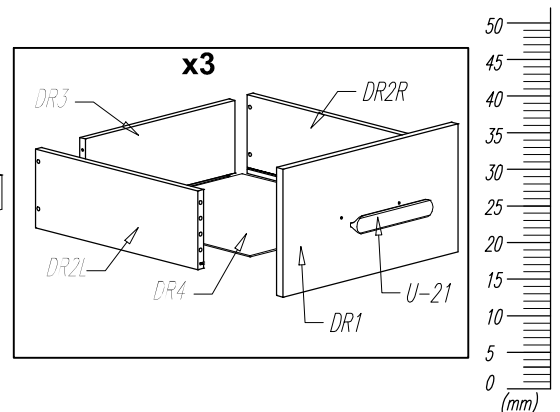
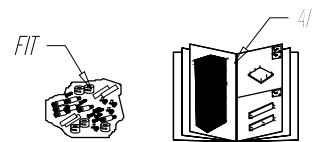

A ø8x40 x62	B L34/St x56	C ø15/16 x56	D ø6,3x40 x12	E x24	F Metal H x2	G EURO ø6x11 x24
H ø3,5x16 x30	K ø3,5x30 x18	L ø7x50 x14	M ø3,0x16 x6	N x4	P ø17 białe x15	Q ø3,5x20 x8
X1 Met+/NK x12	X2 Met+/H0 x12	X3 ø4,0x16 x24+4	R ø18 dqb x2	S x8	T ø4,0x40 x1	ZL ZR FAV-Q/L-450mm x3
2/14	U Odbojnik x8	W L3mm Coli Met+ Coli x2	SW4 x1	LOGO Pinio www.pinio.com.pl x1	OAKIE W3	

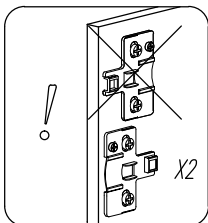
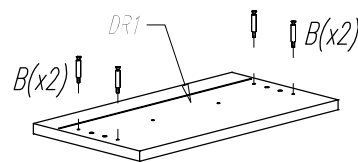
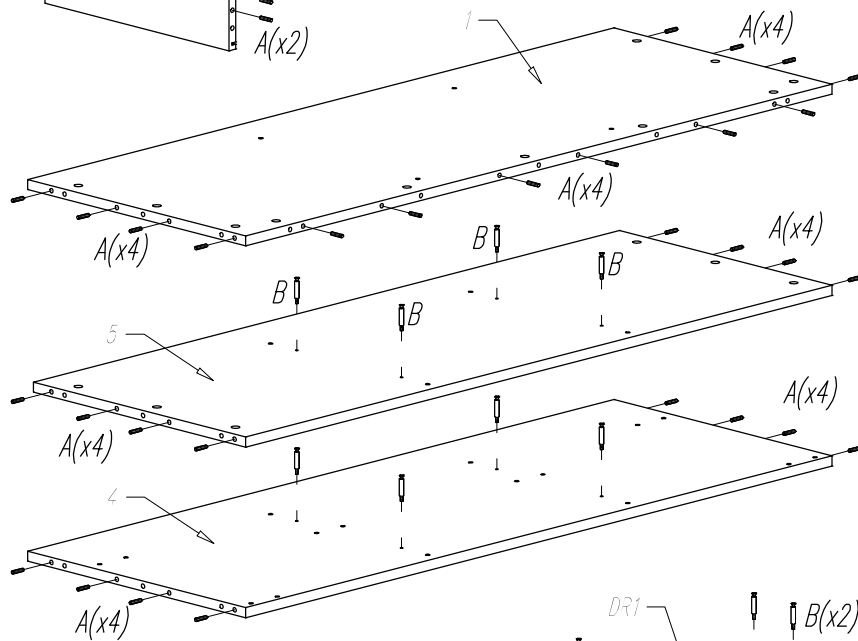
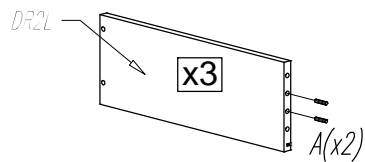
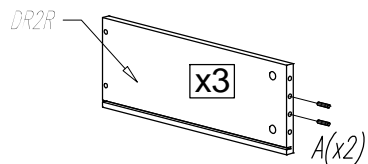
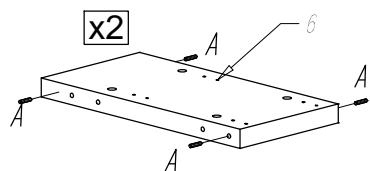
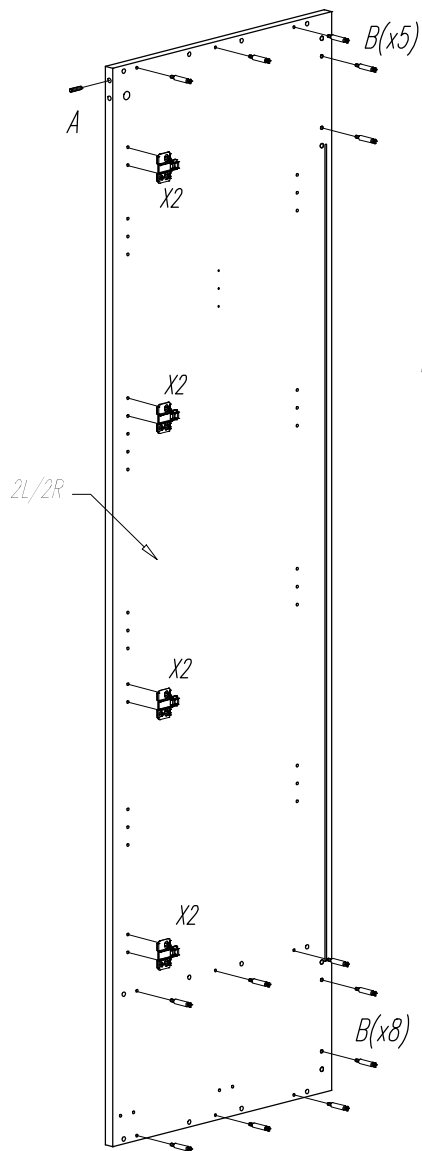
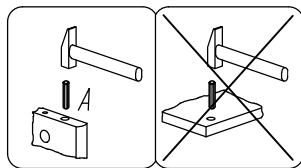
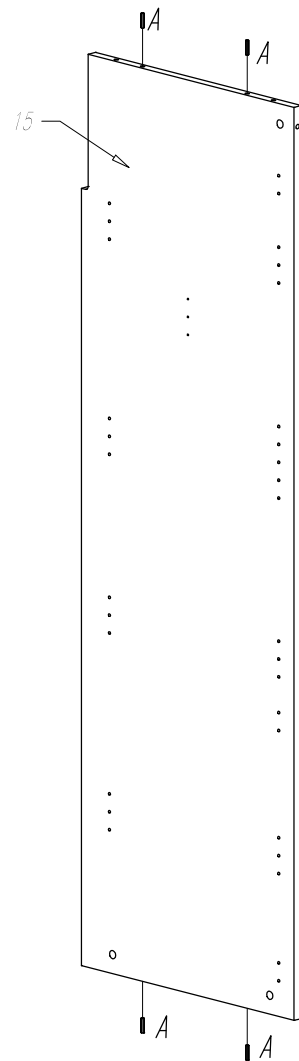
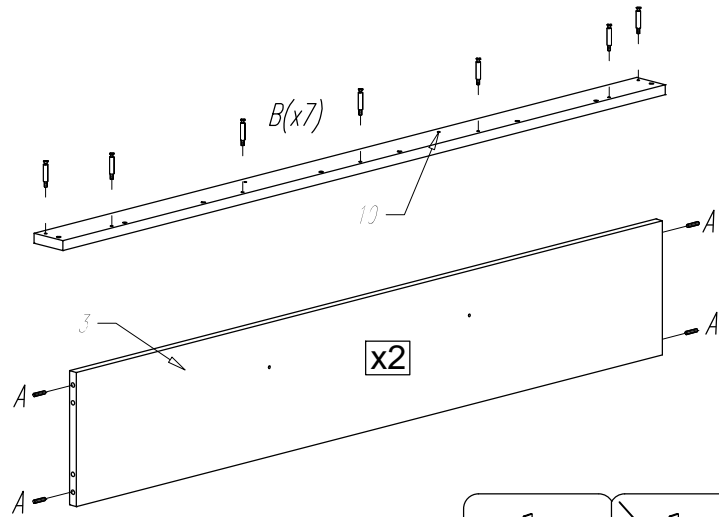
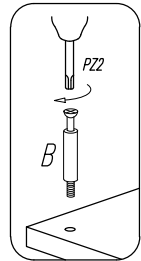

x3

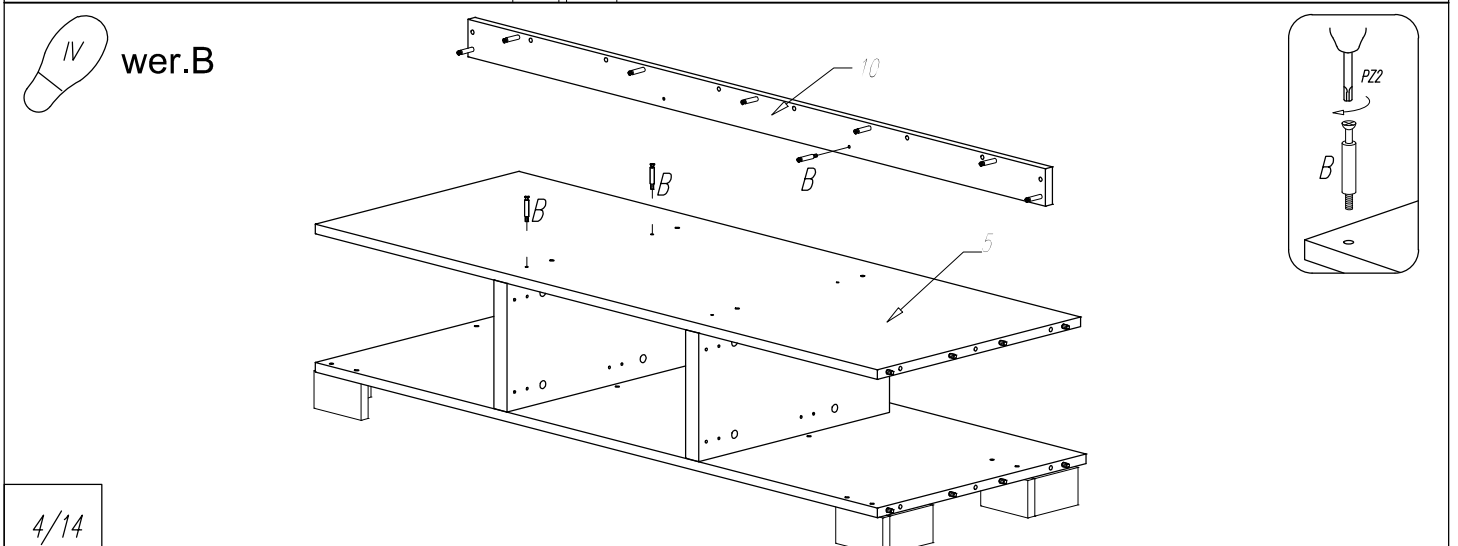
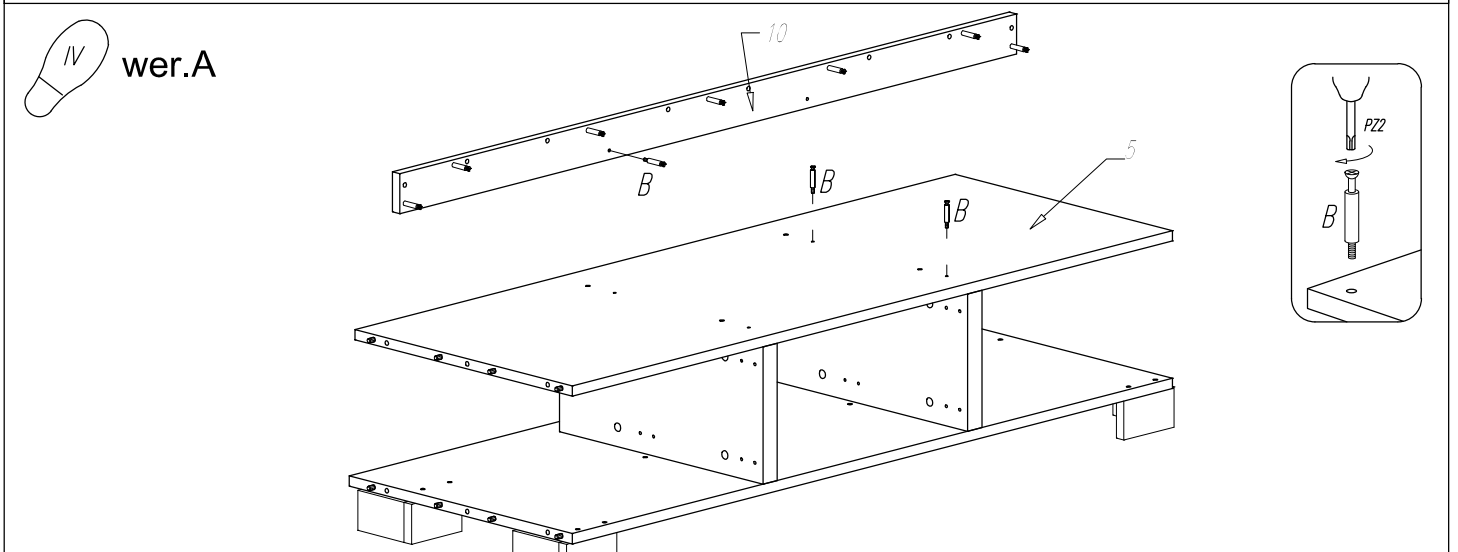
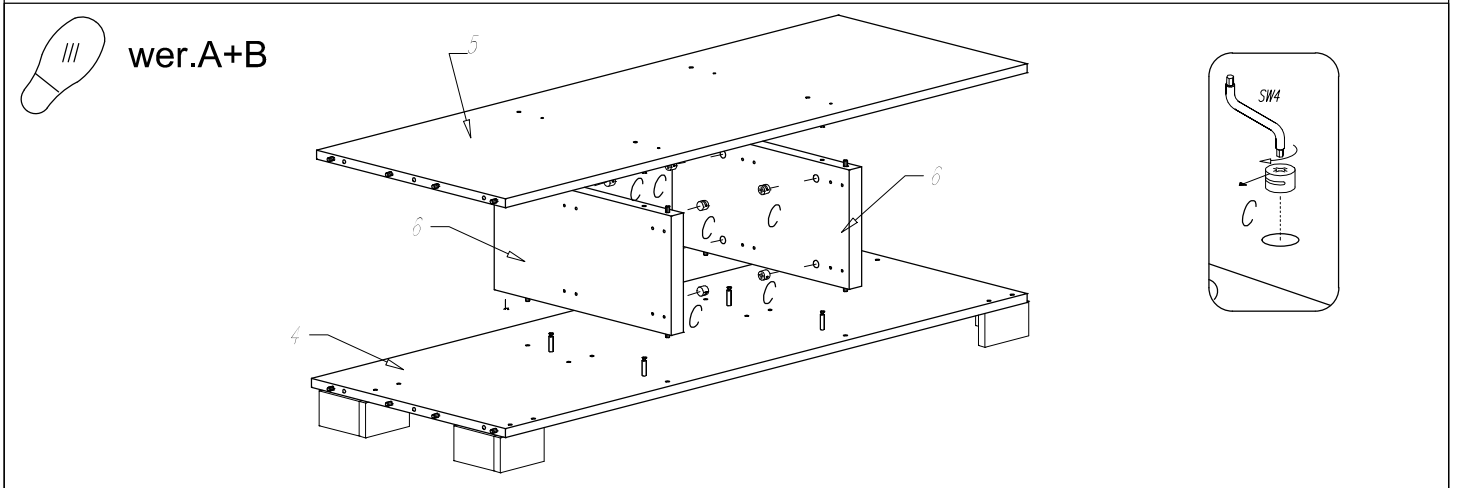
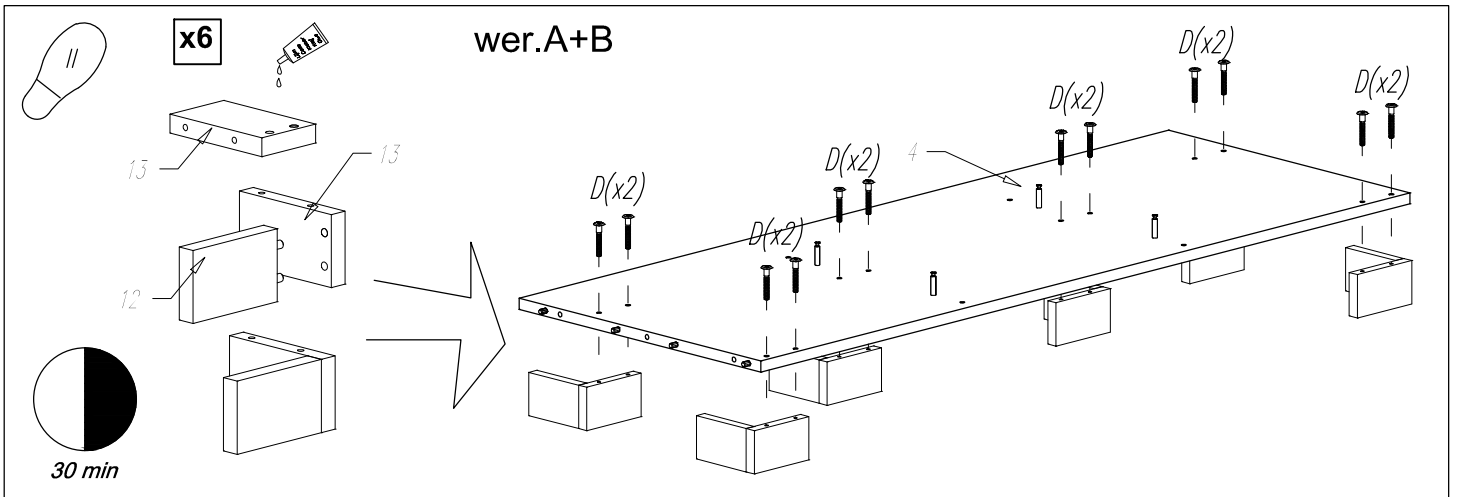



wer.A

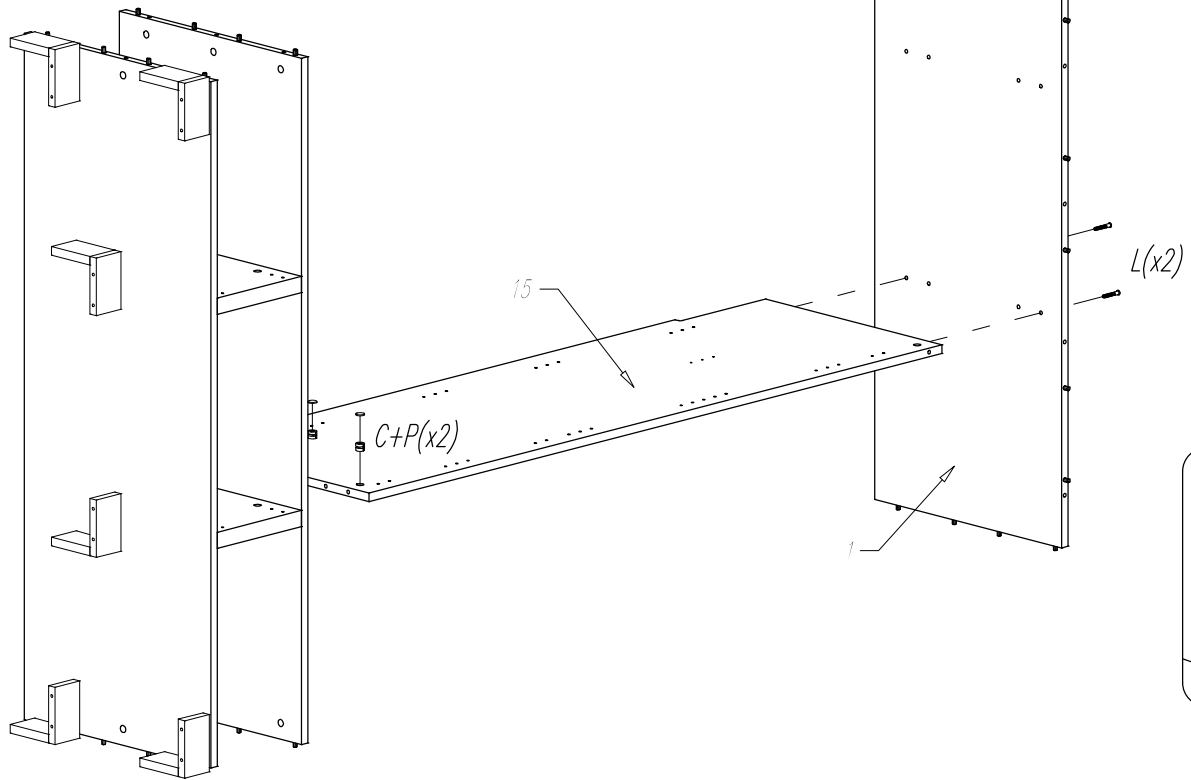

wer.B

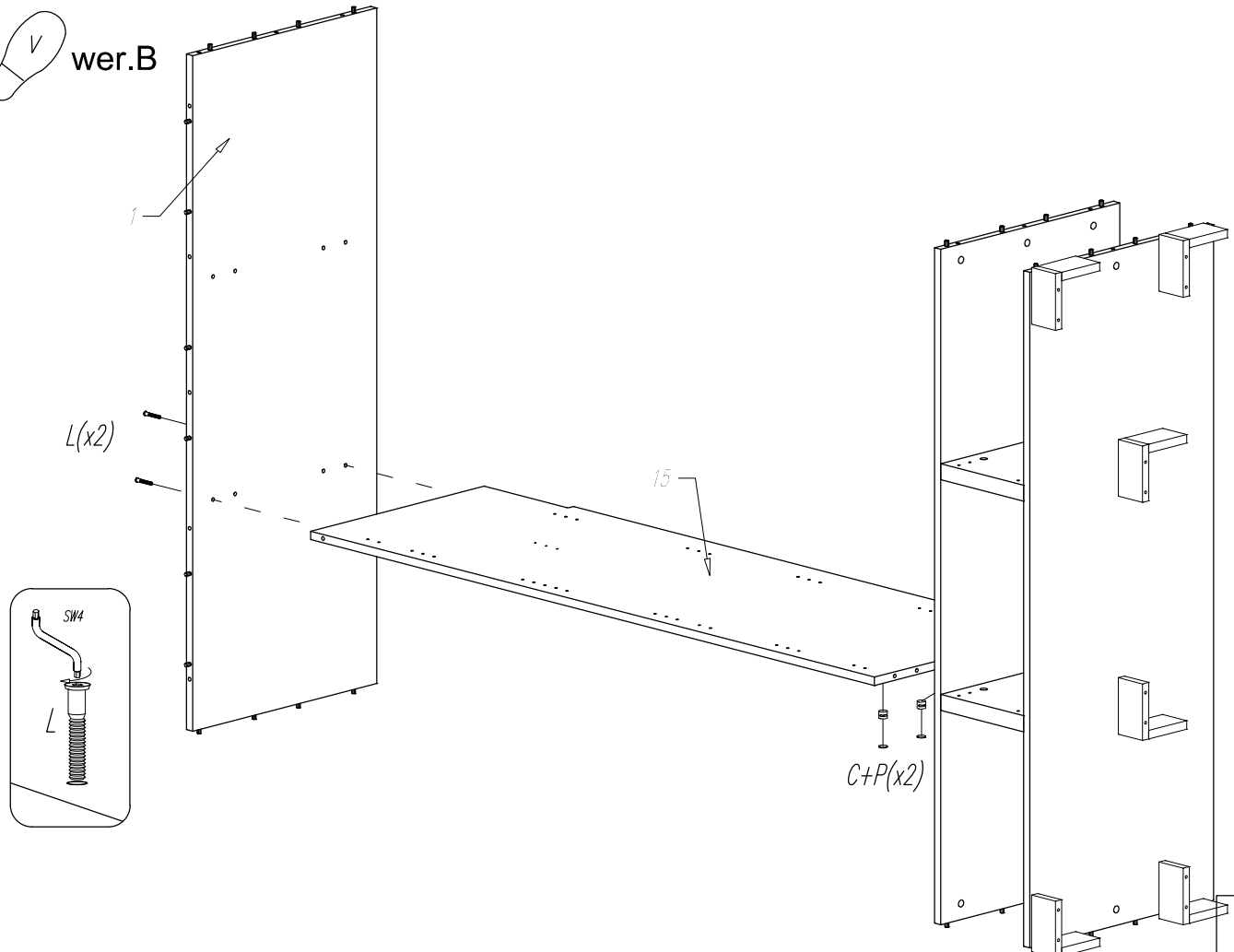

VI wer.A

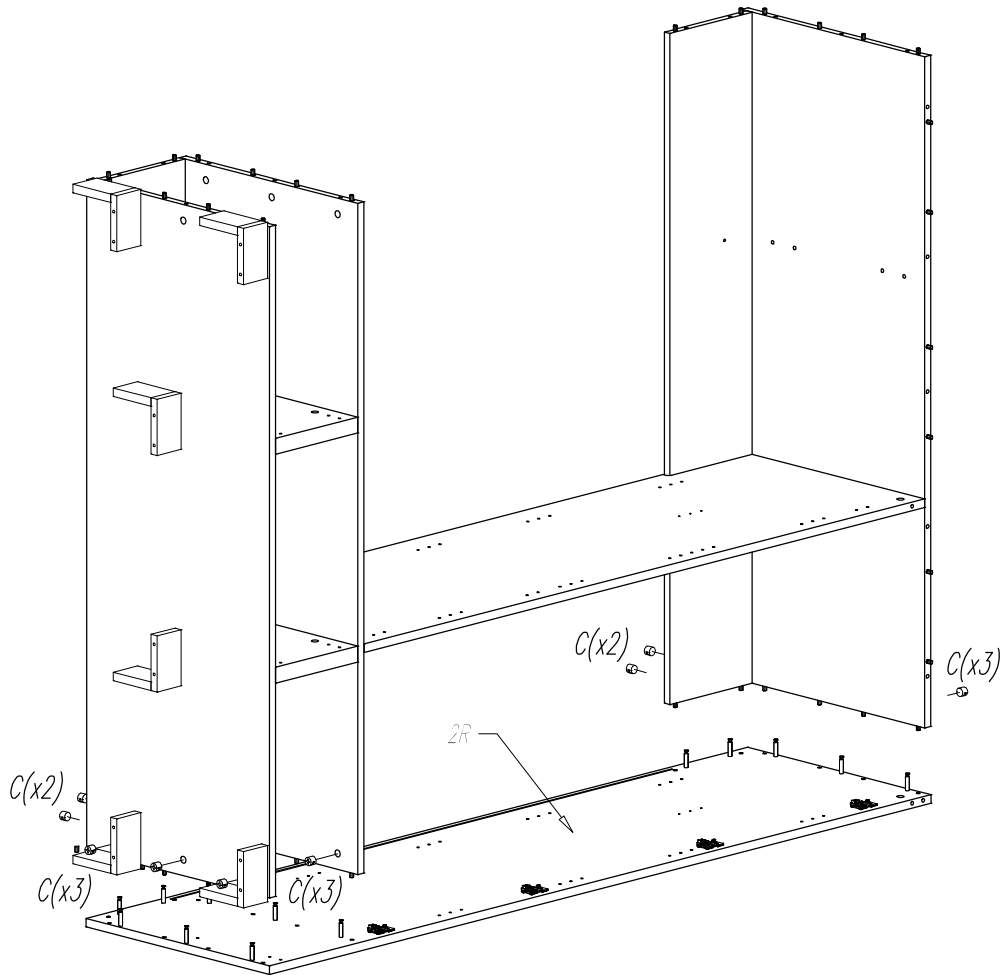

VI wer.B

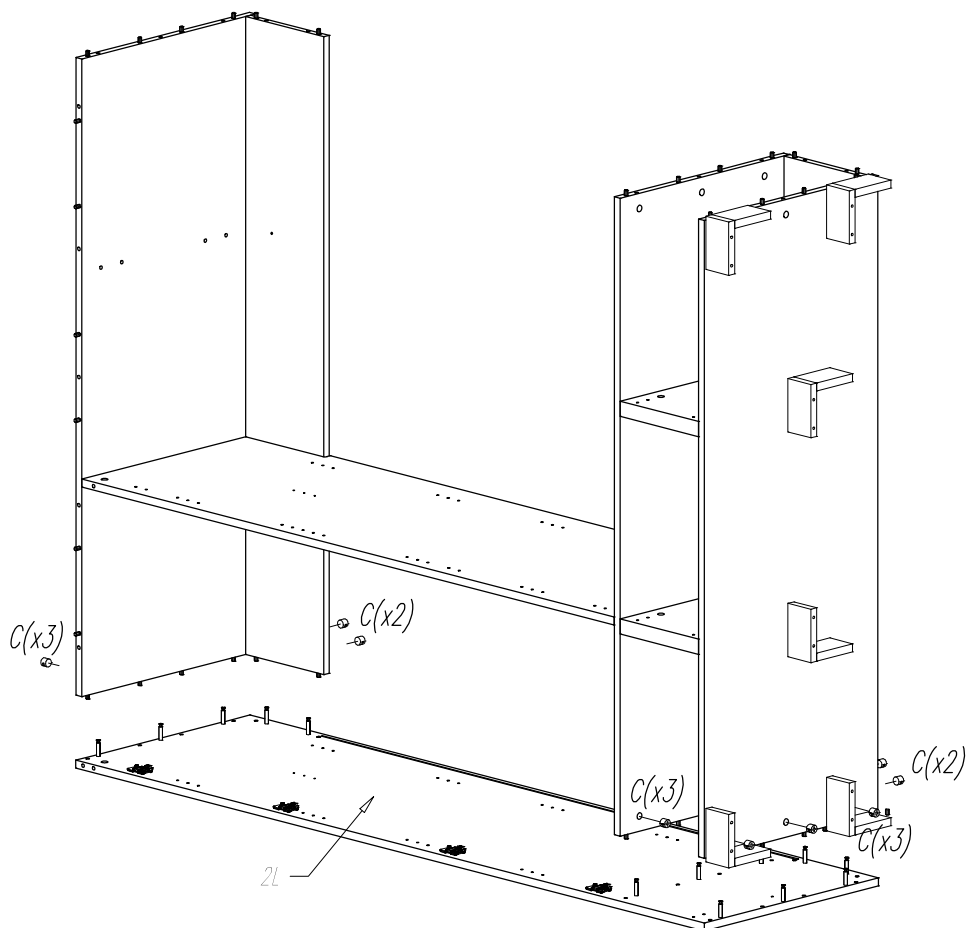



wer.A

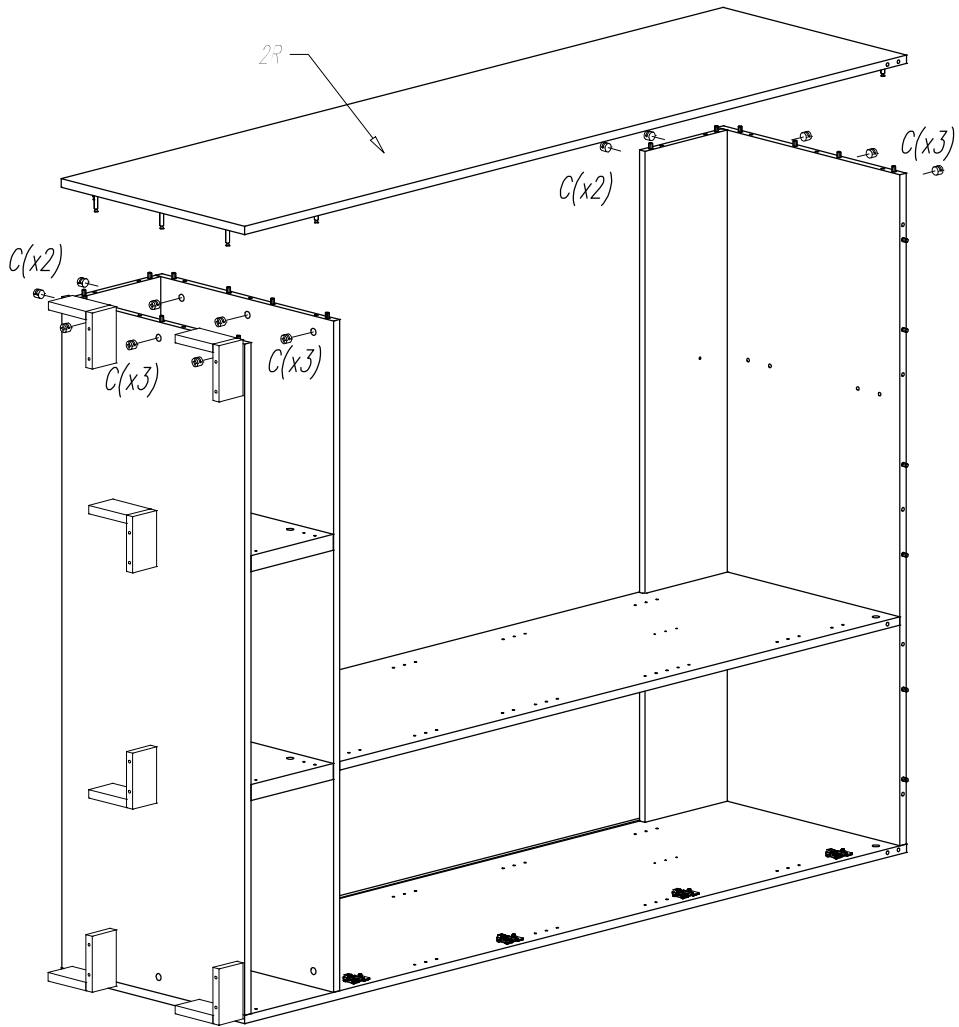

wer.B

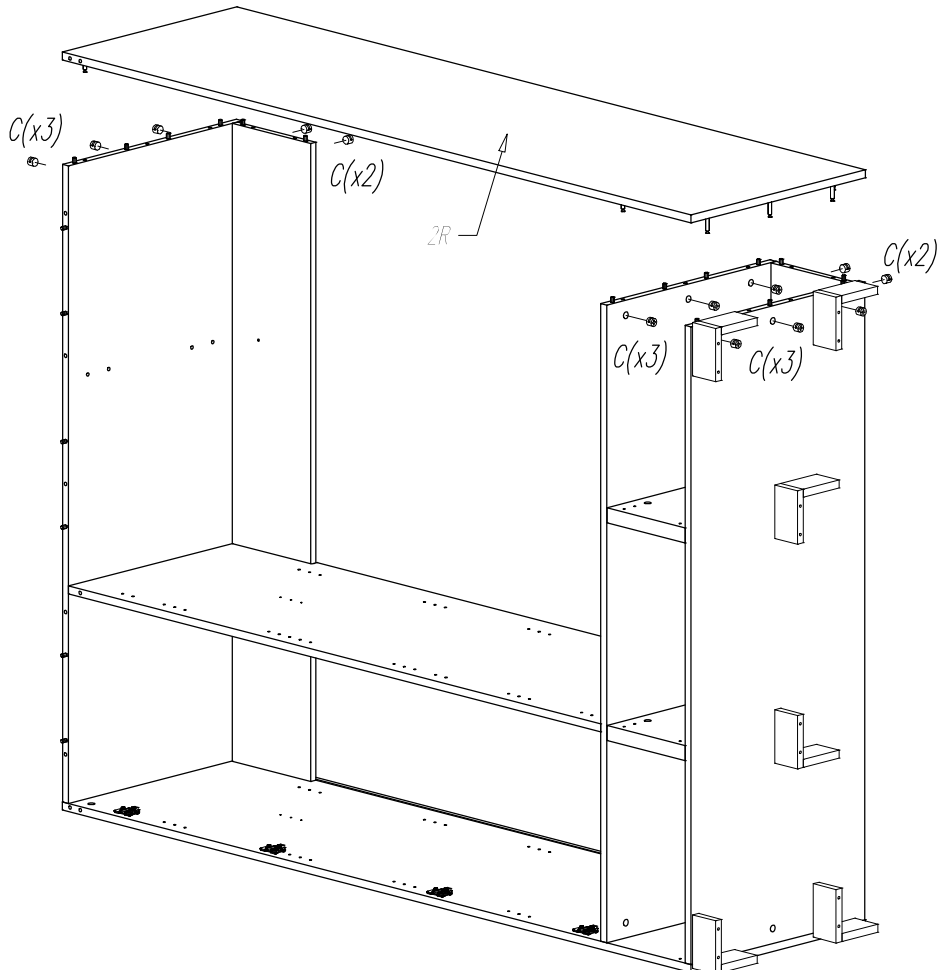



wer.A

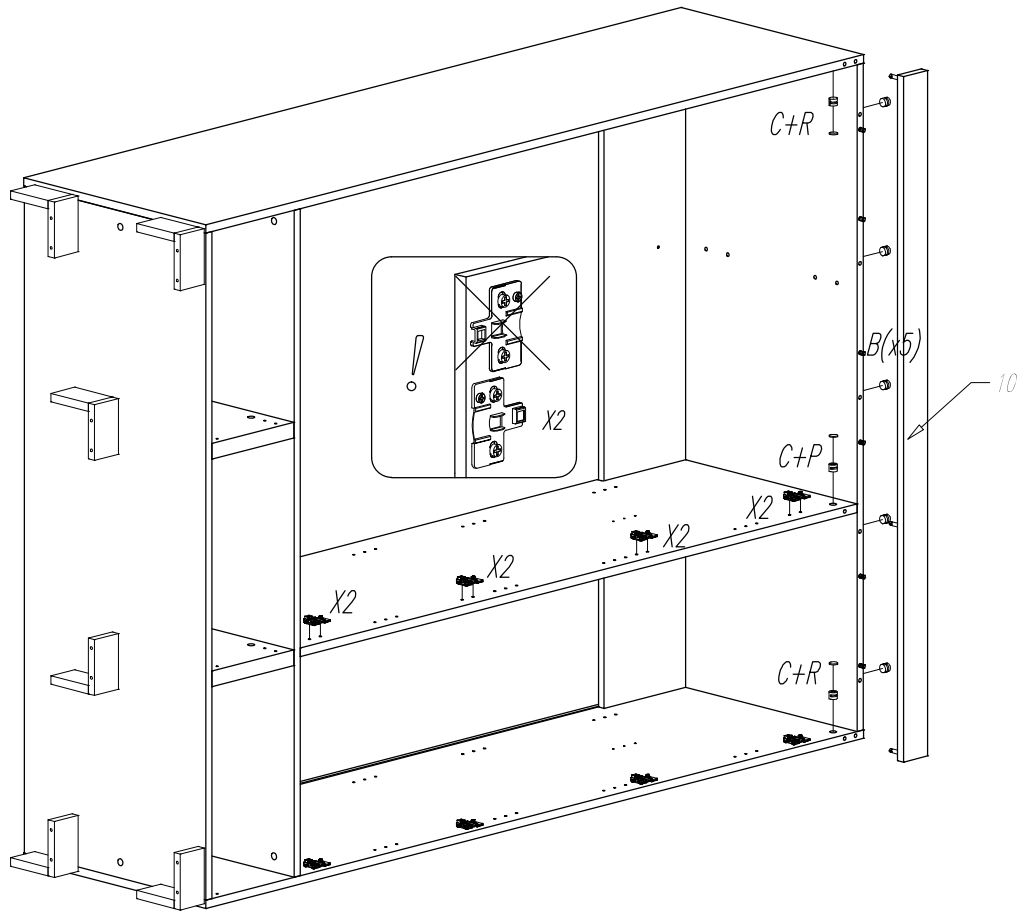

wer.B

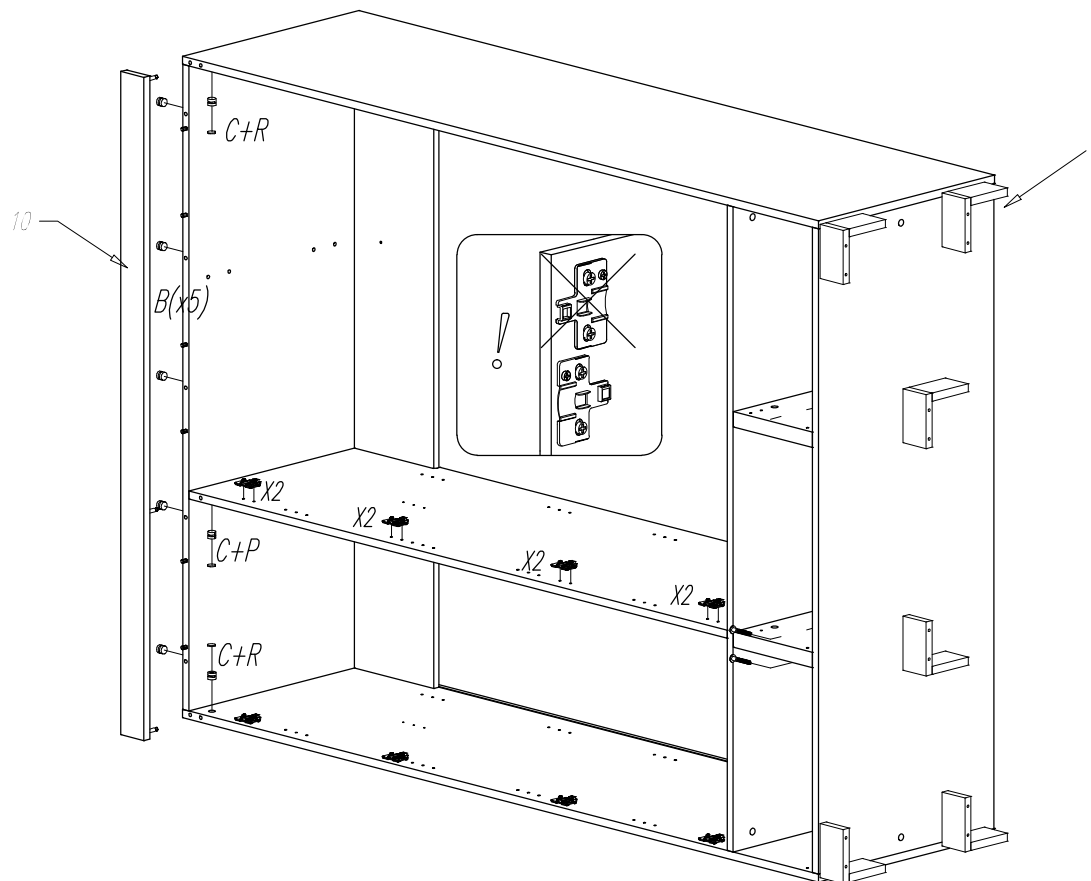



wer.A

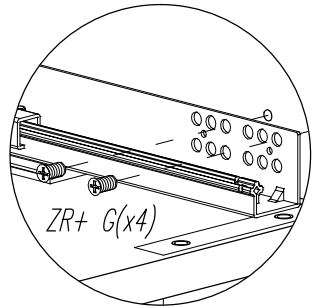
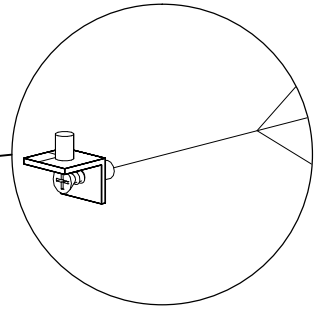
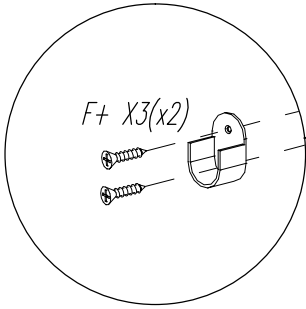
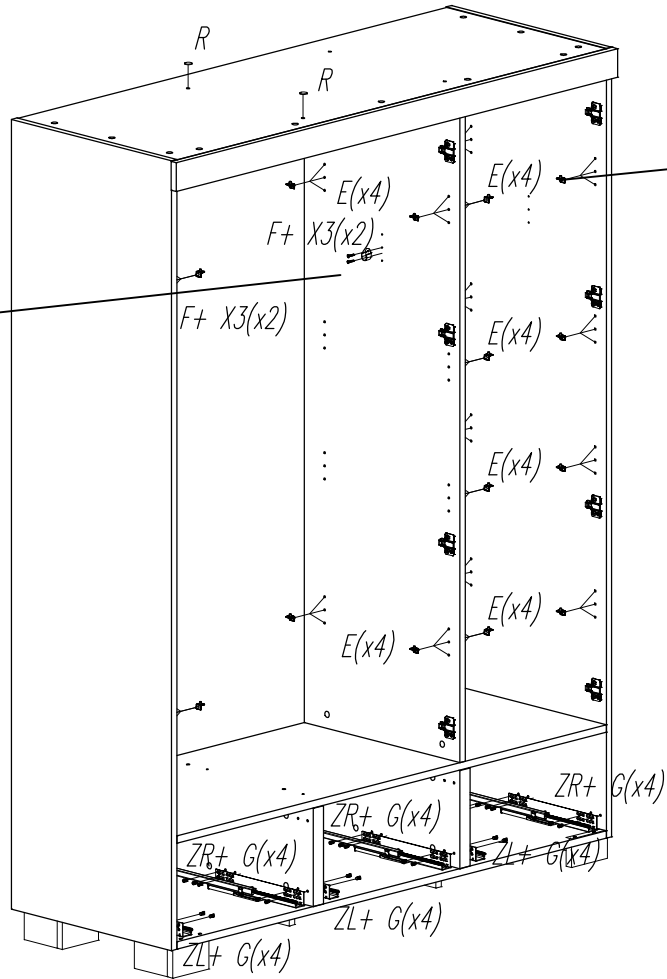

wer.B

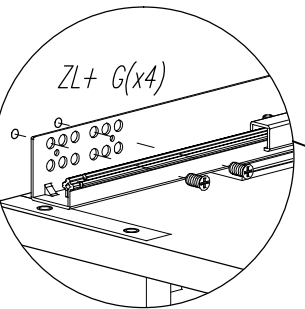
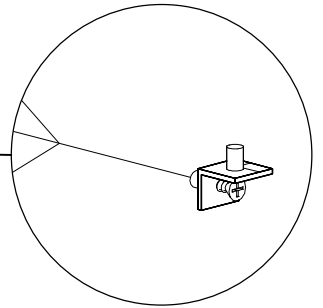
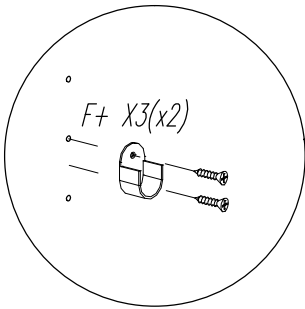
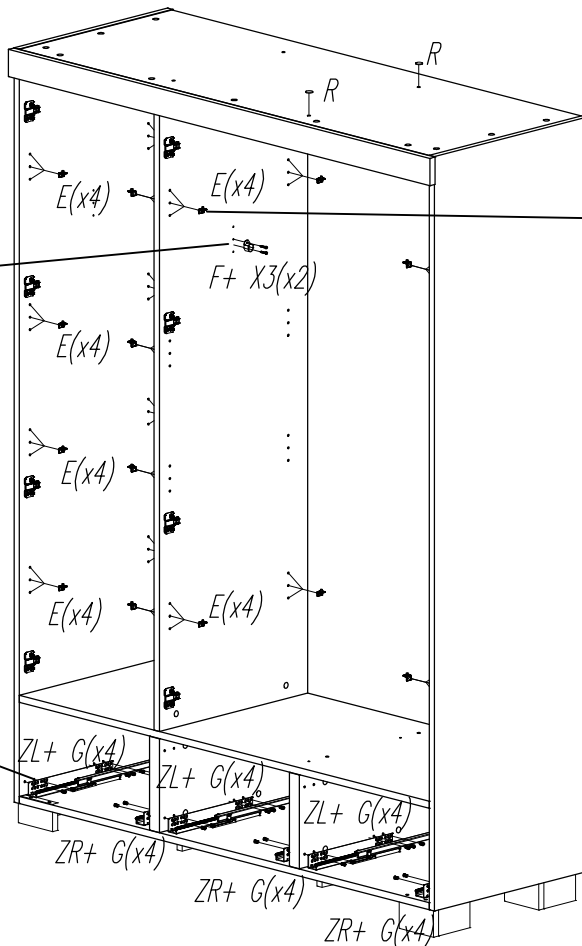



wer.A

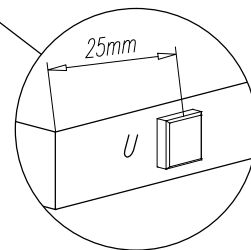
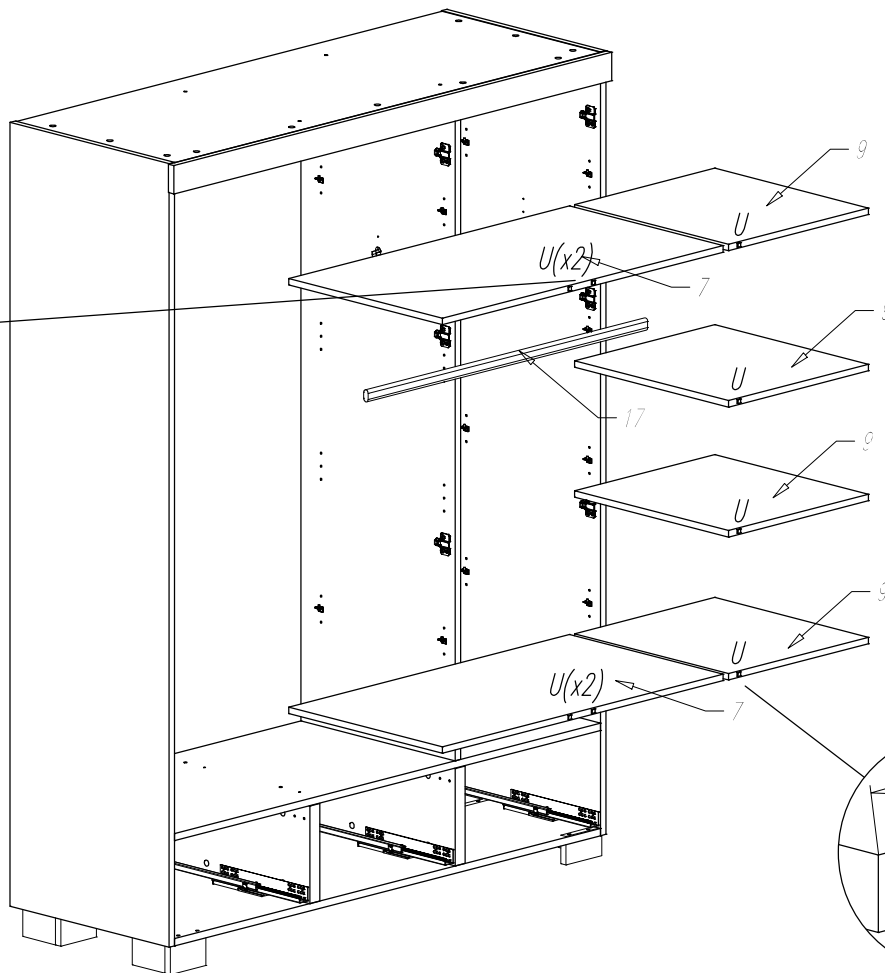
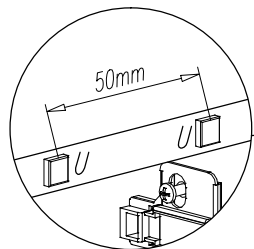

wer.B

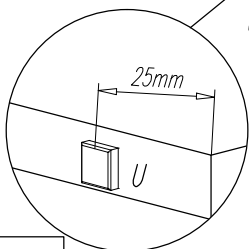
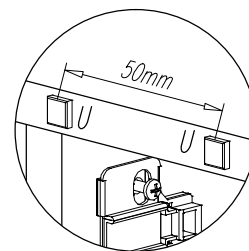
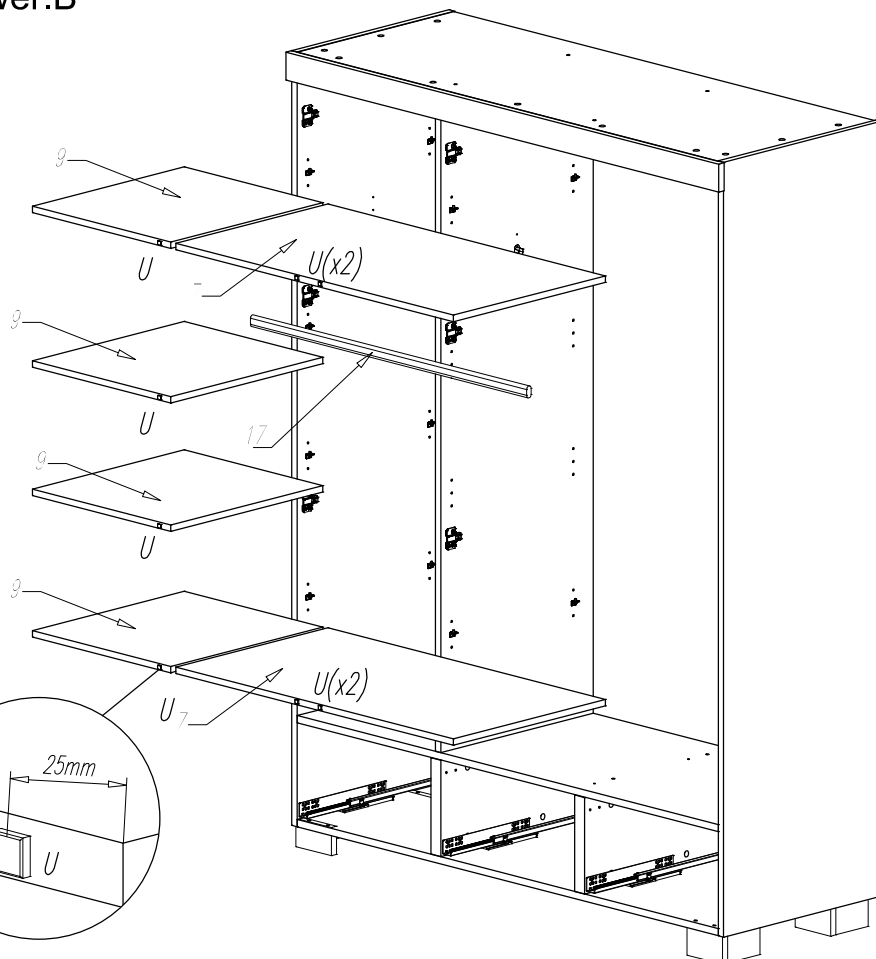



wer.A

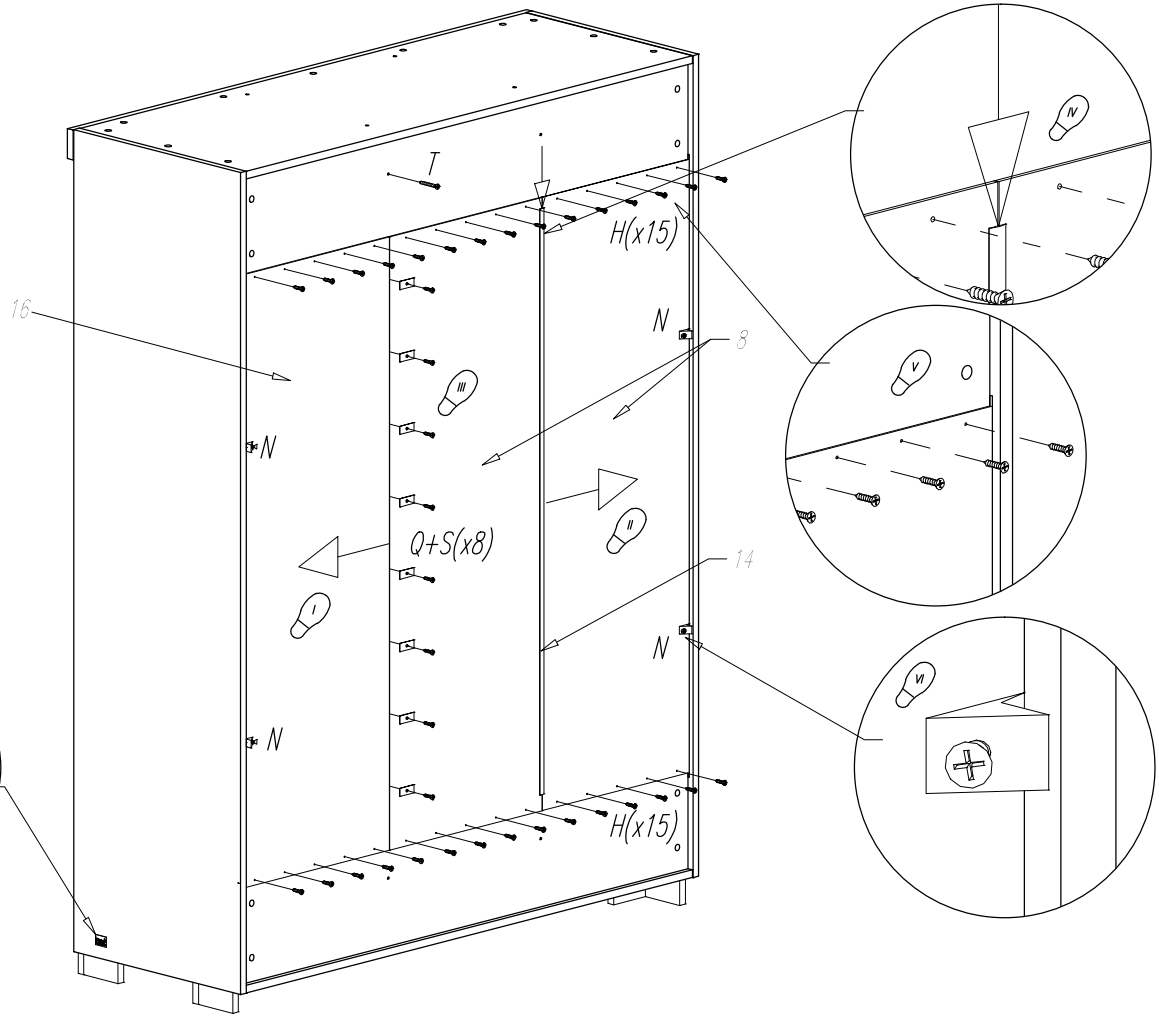
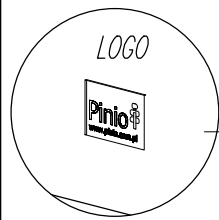

wer.B

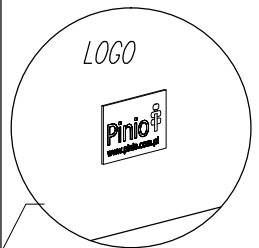
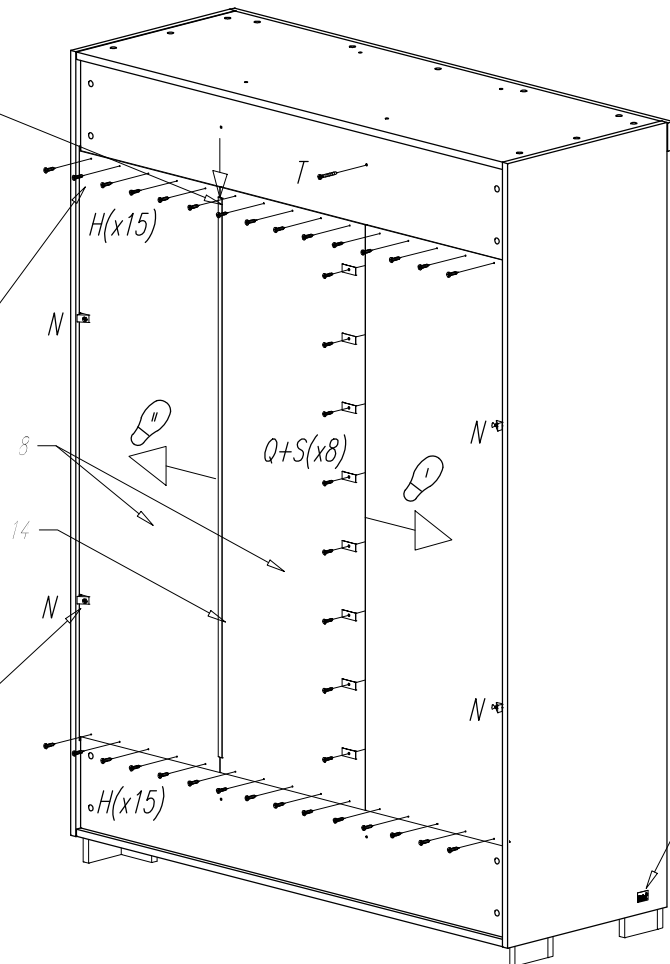
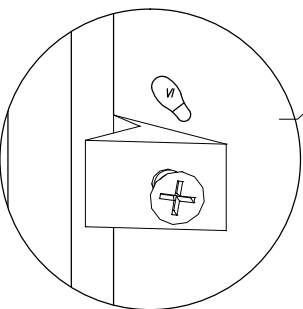
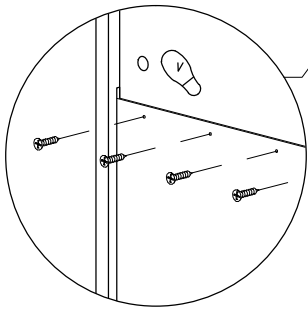
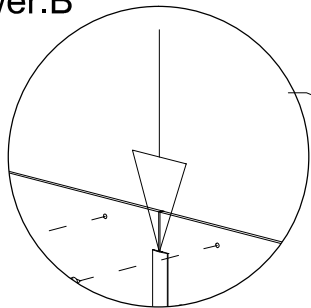

XII

wer.A+B

x3

X1+X3(x2)

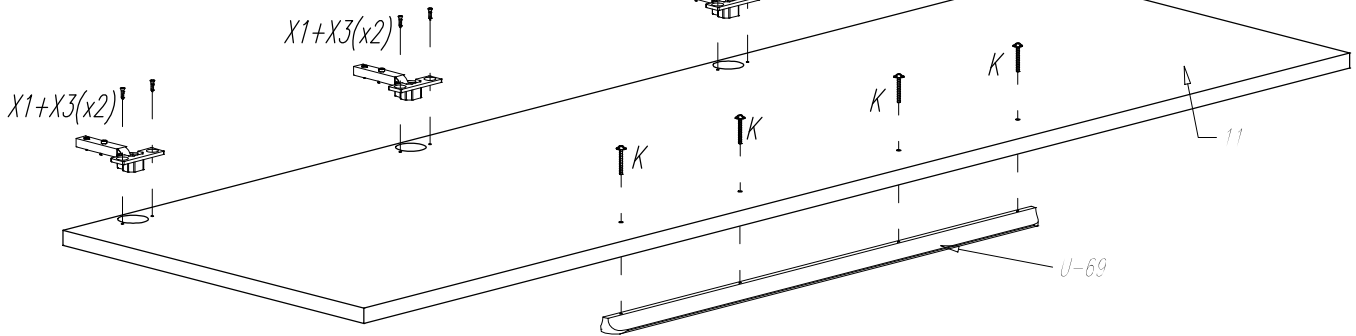
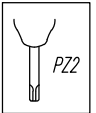

XIII

wer.A+B

x3

L(x2)

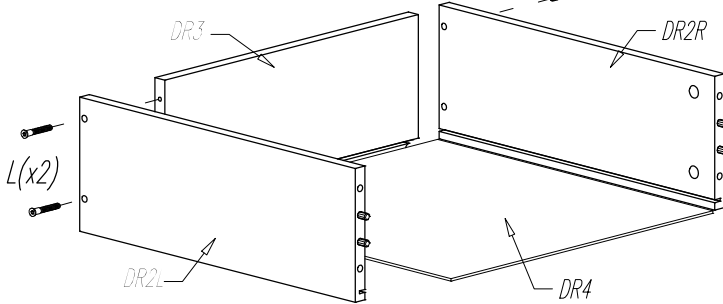

x3

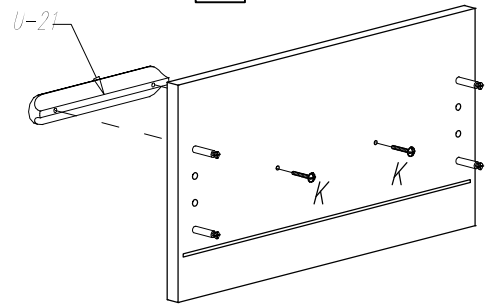

x3

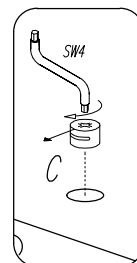
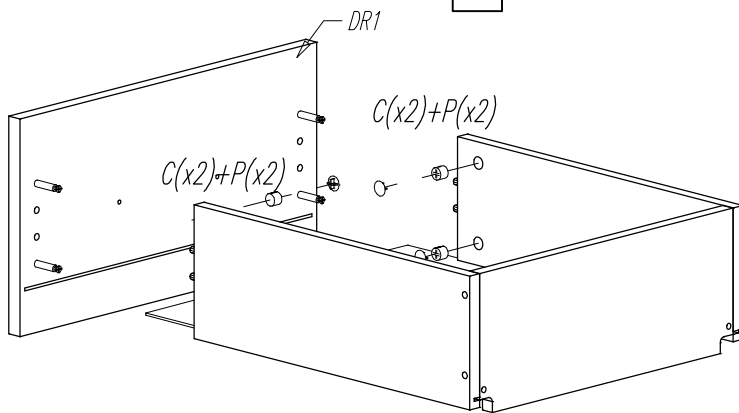

XIII
wer.A

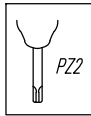
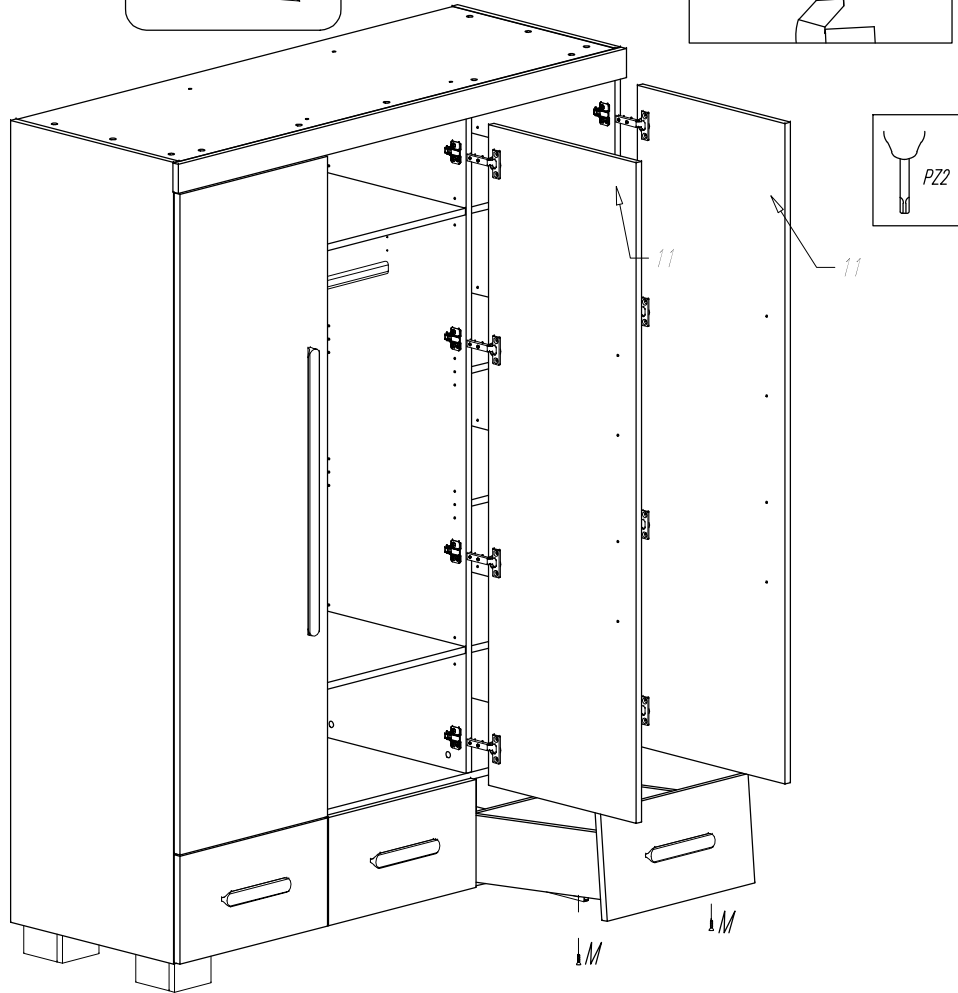
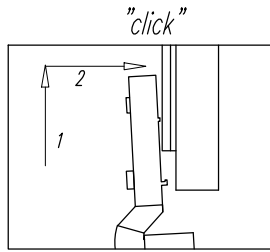
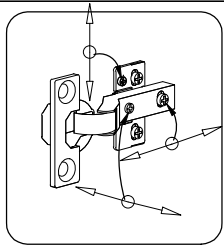

XIII
wer.B

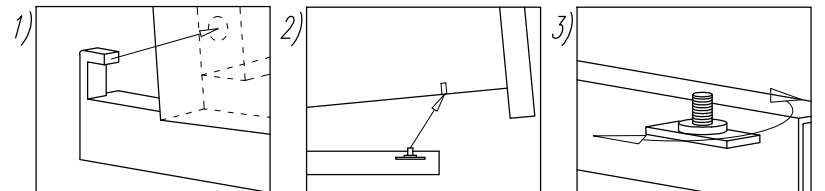
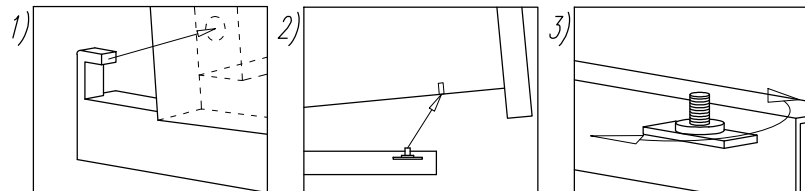
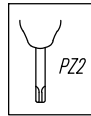
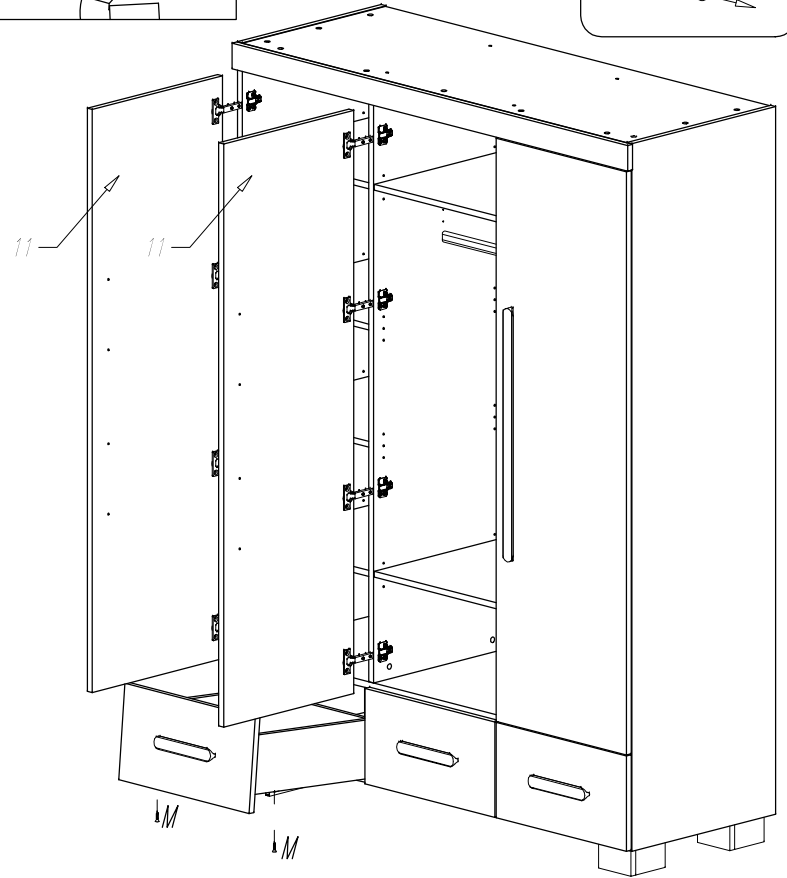
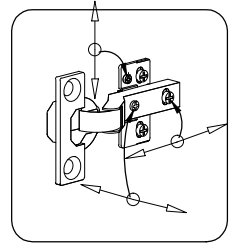
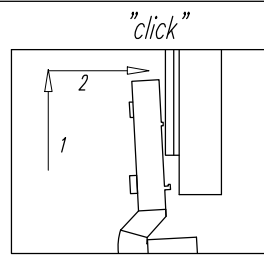



Zabezpieczenie przed przewracaniem

Kippsicherung

Prevention of tipping over

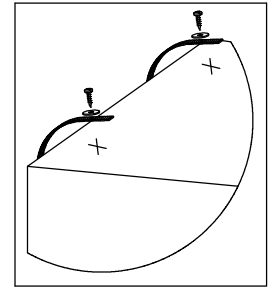
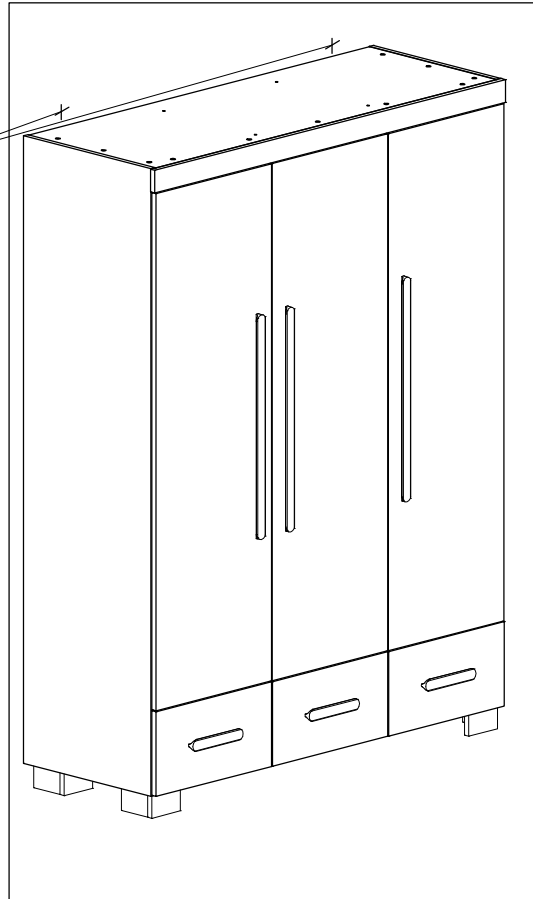
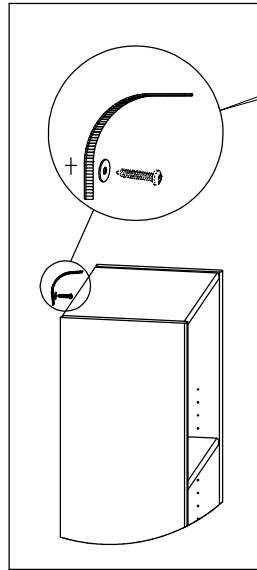
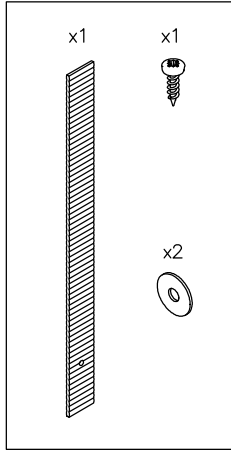
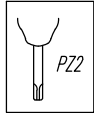

PL

Konieczny jest montaż do ściany.

Ponieważ materiał, z którego wykonano ścianę może być inny w każdym mieszkaniu, w komplecie nie znalazły się żadne umocowania ani wkręty. Aby uzyskać poradę w kwestii doboru odpowiednich wkrętów skontaktuj się z lokalnym sklepem specjalistycznym.

GB

Wall mounting is required.

As wall materials vary, screws for fixing to wall are not included. For advice on suitable screw systems, contact your local specialized dealer.

DE-AT

Wandmontage ist erforderlich.

Da es viele verschiedene Wandmaterialien gibt, sind Schrauben für die Wandbefestigung nicht beige packt. Ggf. sollte man sich beim Eisenwarenfachhandel nach geeignetem Befestigungsmaterial erkundigen.

FR

Un montage mural est indispensable.

Les vis et ferrures pour fixer le meuble/l'objet au mur ou au plafond ne sont pas incluses. Choisissez des vis et ferrures adaptées au matériau de votre mur. En cas de doute, demandez conseil à un vendeur spécialisé.

SI:

Potrebna montaža na steno.

Ker se stenski materiali razlikujejo, vijaki za pritrditev na steno niso vključeni. Za nasvete o primernih vijačnih sistemih se obrnite na lokalnega specializiranega prodajalca.

HR:

Potrebna je ugradnja na zid.

Budući da postoje različiti materijali od kojih su zidovi izrađeni, vijci za zidnu montažu nisu uključeni. Za savjet o odgovarajućim vijcima se obratite specijaliziranom prodavaču.